

INSTALLATION INSTRUCTIONS

Pro-Line60

Maximum door weight is 60kg

Frames are designed to accept a standard door thickness of 35mm, however 90mm and 100mm frames can be made to accept thicker doors. The frames include quality door hardware supplied by Brio.

Use of 70mm and 75mm frames is not recommended for bathrooms and laundries where moisture may cause the doors or rails to warp.

1. CHECK

Check that you have purchased the correct Cavity Door Frame for your unclad wall (stud) thickness, lining thickness, door size and door thickness. The design allows for the door to slide into the frame and be flush with the split jambs. **1**

If you require the door to project into the opening, when fully open, pack behind the door stop on the post or install a wider door.

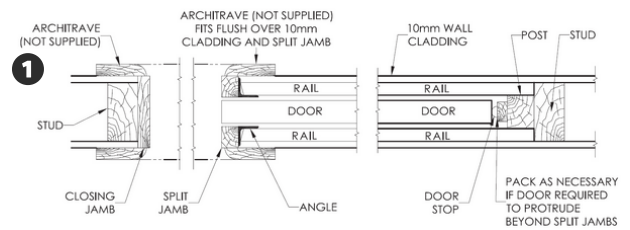

2. PREPARE THE OPENING

Opening width (stud to stud) **2**

Single door: Door width x 2 + 60mm (for door flush with split jambs)

Double door: Door width x 4 + 60mm (for doors flush with split jambs)

Opening height (floor to trimmer) = door height + 75mm

Frames are designed to fit onto the floor surface (i.e. concrete/timber) before floor coverings.

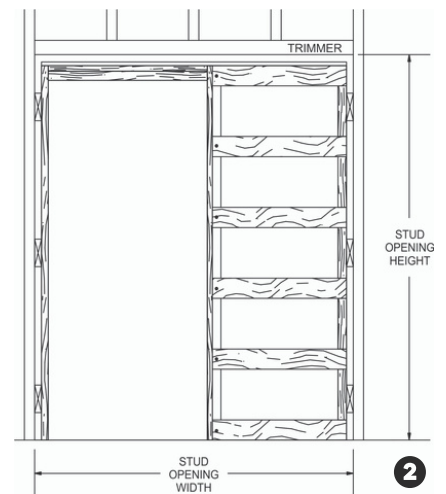

3. CLEARANCE UNDER THE DOOR

The clearance under the door is approximately 26mm. This gap may be taken up by floor covering e.g. carpet, tiles, vinyl etc. If you require more than 26mm clearance under the door, pack the cavity door frame off the floor by the required amount.

4. ASSEMBLE THE FRAME

The aluminium head-track is to be screwed down to the top of the frame with the split head against the split jamb. Cut the closing jamb to the exact length you require, then screw it to the underside of the aluminium head-track against the split head. **3**

The frame must be installed with the head-track level. Screw the track to the trimmer through the holes in the centre of the track.

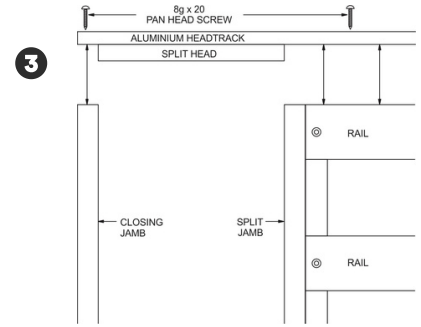

5. INSTALL THE FRAME

Ensure that the floor is level beneath the frame. Place frame into opening, ensuring that it is square, plumb and level. Pack as necessary between POST and STUD and fix off to framework and floor.

IMPORTANT

6. FIT HANGER PLATES

Rebate two 7mm deep (max) recesses in the top of the door 70mm in from each end. Fit hanger plates to the top of the door, one in each recess, with the lock tabs both on the same side of the door. **4**

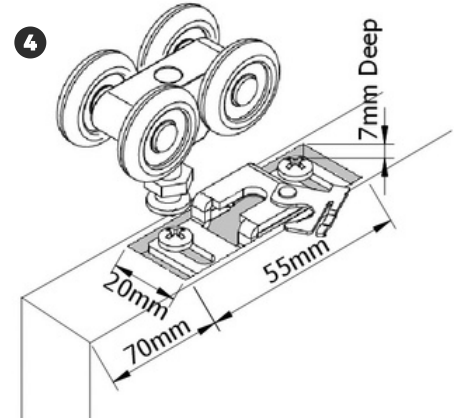

7. HANG DOOR

Insert wheels into the track. Place the door in line with the track and insert hanger bolt head into the slot in the hanger plate. Lock the bolt in place with the lock tabs. **5**

Adjust bolt to height required. **6**

We recommend you hang the door temporarily before the plaster board is fitted to make sure the cavity slider fittings are correctly installed.

However, we recommend that you remove the door again before plaster board is fitted and only rehang the door when plaster is dry and the door has been completely sealed and painted.

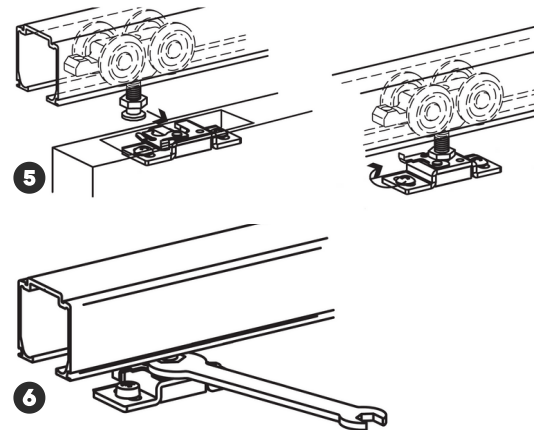

8. SECURE CLOSING JAMB

Position the CLOSING JAMB to suit the door when closed, then pack and secure the closing jamb in place.

9. GUIDES

Screw the wedge guides to the split jambs and adjust vertically so that the door can move freely between the guides.

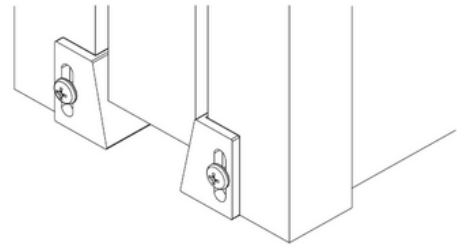

10. ARCHITRAVES

Once the wall has been clad, fit architrave around the jambs and split head, being careful that nails do not penetrate through rails.

11. TO REMOVE DOOR

The door can be removed by reversing procedures 10, 9, 7 & 6.

12. DOUBLE DOOR INSTALLATION

Assemble frames and install as per steps 4, 5, 6 & 7. Double units come standard with one-piece double head-track and two track-stops. **7**

Double frames must be level plumb and checked for alignment (no twist) so doors line up in the closed position.

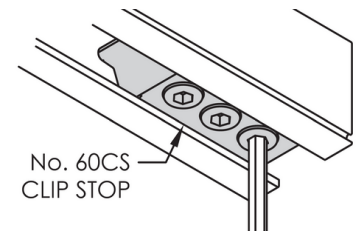
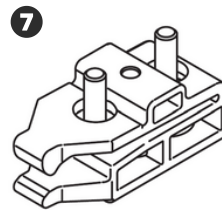

13. CHECK DOOR OPERATION BEFORE THE FRAME IS CLAD

Once the doors are installed, position the track-stops in the head-track where the doors meet, so that neither of the doors slide fully out of the cavity, past the guides. Once they are in place tighten the screws to secure.

14. FIT SOFT CLOSES

Soft close - install as per Soft Closer 60kg Installation

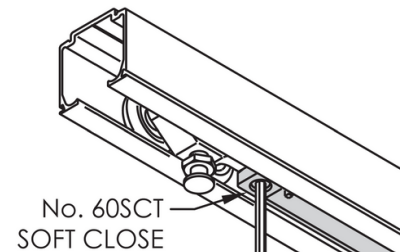

PRODUCT IMPROVEMENT IS A CONTINUOUS
PROCESS & SPECIFICATIONS ARE SUBJECT TO
CHANGE WITHOUT NOTICE
© COPYRIGHT 2023 E&OE