



# Installation Guide

Hardie™ Oblique™ & Stria™ Cladding  
Horizontal Orientation

## EXTERIORS

Australia May 2024

**Make sure your information is up to date.**

When specifying or installing Hardie™ products, ensure that you have the current technical information and guides. If in doubt, or you need more information, visit [jameshardie.com.au](http://jameshardie.com.au) or contact James Hardie on 13 11 03.

## CONTENTS

1	INTRODUCTION	2
2	SAFE WORKING PRACTICES	3
	Warning	3
	Recommended safe working practices	3
	Storage and handling	3
3	DESIGN CONSIDERATIONS	3
	Framing	4
	Fasteners	4
4	PRODUCTS AND ACCESSORY DETAILS	7
	Components	7
	Tools	8
5	PANEL INSTALLATION - HORIZONTAL DIRECT FIX	9
6	PANEL INSTALLATION - HORIZONTAL CAVITY FIX	10
7	CONSTRUCTION DETAILS - DIRECT FIX	11
	Junction Details	11
	External Corner Details	11
	Internal Corner Details	11
	Joint Details	12
	Window Details	12
8	CONSTRUCTION DETAILS - CAVITY FIX	13
	Junction Details	13
	External Corner Details	13
	Internal Corner Details	13
	Joint Details	14
	Window Details	14
9	FINISHES AND MAINTENANCE	15
	Surface Preparation	15
	Painting	15
	Maintenance	15
10	PRODUCT INFORMATION	15
11	SITE INSTALLATION CHECKLIST	16

## SCOPE

This guide covers the use of Hardie™ Oblique™ Cladding and Stria™ Cladding Horizontal in a residential wall application over a seasoned timber wall frame or a light-gauge steel frame installed in a vertical upright application.

## CODEMARK CERTIFICATION

The CodeMark Certification Scheme is a voluntary third-party building product certification scheme that authorises the use of new and innovative products in specified circumstances in order to facilitate compliance with Volume 1 and 2 of the NCC.

Hardie™ Oblique™ Cladding and Stria™ Cladding has been certified under the CodeMark scheme (Certificate Number CM40223) and available at [www.jameshardie.com.au](http://www.jameshardie.com.au). This certificate can be provided to building certifiers and other regulatory authorities to facilitate the assessment of the product compliance or used to verify the suitability of the product for certain applications.



# 1 Introduction

## Create diverse modern designs with Hardie™ Oblique™ Cladding and Stria™ Cladding.

Stria™ Cladding has a simple U-shaped groove spaced at 300mm or 380mm depending on the chosen size. Hardie™ Oblique™ Cladding has an asymmetrical groove with one square edge and a long oblique or slanting edge, the groove spacing is 175mm and 275mm depending on the profile. Both products can be installed in vertical or horizontal orientation for different looks.

**Horizontal Orientation.** The cladding boards fixed direct to frame with the shiplap joints making installation simple and fast. Stria™ Cladding gives distinctive lines of large format shiplap boards. Hardie™ Oblique™ Cladding, on the other hand, with its slanted groove edge is reminiscent of a rusticated shiplap weatherboards.

## IMPORTANT NOTES

1. Failure to install, finish or maintain this product in accordance with applicable building codes, regulations, standards and James Hardie's written application instructions may lead to personal injury, affect system performance, violate local building codes, and void James Hardie's product warranty.
2. All warranties, conditions, liabilities (direct, indirect or consequential) and obligations whether arising in contract, tort or otherwise other than those specified in Hardie™ product warranty are excluded to the fullest extent allowed by law. For Hardie™ product warranty information and disclaimers about the information in this guide, visit [www.jameshardie.com.au](http://www.jameshardie.com.au).
3. The builder must ensure the product meets aesthetic requirements before installation. James Hardie will not be responsible for rectifying aesthetic surface variations following installation.

# 2 Safe Working Practices

## WARNING - DO NOT BREATHE DUST AND CUT ONLY IN WELL VENTILATED AREA

Fibre cement products manufactured by James Hardie contain sand, a source of respirable crystalline silica. **May cause cancer if dust from product is inhaled. Causes damage to lungs and respiratory system through prolonged or repeated inhalation of dust from product.** Intact fibre cement products are not expected to result in any adverse toxic effects. The hazard associated with fibre cement arises from the respirable crystalline silica present in dust generated by activities such as cutting, rebating, drilling, routing, sawing, crushing, or otherwise abrading fibre cement, and when cleaning up, disposing of or moving dust. When doing any of these activities in a manner that generates dust, follow Hardie™ instructions and best practices to reduce or limit the release of dust, warn others in the area and consider rotating personnel across the cutting task to further limit respirable silica exposure. If using a dust mask or respirator, use an AS/NZS1716 P1 filter and refer to Australian/New Zealand Standard 1715:2009 Selection, Use and Maintenance of Respiratory Protective Equipment for more extensive guidance and more options for selecting respirators for workplaces. For further information, refer to our installation instructions and Safety Data Sheets available at [www.jameshardie.com.au](http://www.jameshardie.com.au). FAILURE TO ADHERE TO OUR WARNINGS, SAFETY DATA SHEETS, AND INSTALLATION INSTRUCTIONS MAY LEAD TO SERIOUS PERSONAL INJURY OR DEATH.

### James Hardie Recommended Safe Working Practices

#### CUTTING OUTDOORS

1. Position cutting station so wind will blow dust away from the user or others in working area.
2. Warn others in the area to avoid dust.
3. Consider rotating personnel across cutting tasks to further limit respirable silica exposures.
4. Use one of the following methods based on the required cutting rate:  
**Best** ▪ Villaboard™ knife ▪ Hand guillotine ▪ Fibreshear  
**Better** ▪ Position the cutting station in a well-ventilated area. Use a dust reducing circular saw equipped with Hardie™ Blade Saw Blade or comparable fibre cement blade and well maintained M-class vacuum or higher with appropriate filter for capturing fine (respirable) dust. Wear a properly-fitted, approved dust mask or respirator (minimum P1).

#### CUTTING INDOORS

- Cut only using Villaboard™ knife, hand guillotine or fibreshears (manual, electric or pneumatic).
- Position cutting station in a well-ventilated area.

#### DRILLING/OTHER MACHINING

When drilling or machining you should always wear a P1 dust mask and warn others in the immediate area.

#### IMPORTANT NOTES

1. For maximum protection (lowest respirable dust production) James Hardie recommends always using best practice cutting methods where feasible.
2. NEVER use a power saw indoors or in a poorly ventilated area.
3. ALWAYS use a dust reducing circular saw equipped with a sawblade specifically designed to minimise dust creation when cutting fibrecement - preferably a sawblade that carries the Hardie™ Blade logo or one with at least equivalent performance - connected to a M class or higher vacuum.
4. NEVER dry sweep - Use wet suppression, or an M class vacuum or higher with appropriate filter.
5. NEVER use grinders.
6. ALWAYS follow tool manufacturers' safety recommendations.
7. ALWAYS wear a properly fitted, approved dusk mask, P1 or higher

#### DUST MASKS AND RESPIRATORS

As a minimum, an AS/NZS1716 P1 respirator must be used when doing any activity that may create dust. For more extensive guidance and options for selecting respirators for workplaces please refer to Australian/New Zealand Standard 1715:2009 "Selection, Use and Maintenance of Respiratory Protective Equipment". P1 respirators should be used in conjunction with the above cutting practices to minimise dust exposure. For further information, refer to Safety Data Sheet (SDS) available at [www.jameshardie.com.au](http://www.jameshardie.com.au). If concern still exists about exposure levels or you do not comply with the above practices, you should always consult a qualified industrial hygienist or contact James Hardie for further information.

## STORAGE AND HANDLING

To avoid damage, all Hardie™ products and accessories should be stored with edges and corners of the product protected from chipping. Hardie™ products and accessories must be installed in a dry state and protected from weather during transport and storage. The product must be laid flat under cover on a smooth level surface clear of the ground to avoid exposure to water, moisture, etc.

# 3 Design Considerations

All design and construction must comply with the appropriate requirements of the current National Construction Code (NCC) and other applicable regulations and standards.

## Slab and Footings

The slab and footings on which the building is situated must comply with AS 2870 'Residential slabs and footings – Construction' and the requirements of the NCC.

## Ground Clearances

Install Hardie™ external cladding with a minimum 150mm clearance to the earth on the exterior of the building or in accordance with local building codes if greater than 150mm is required. Maintain a minimum 50mm clearance between Hardie™ external cladding and roofs, decks, paths, steps and driveways.

Adjacent finished grade must slope away from the building in accordance with local building codes, typically a minimum slope of 50mm over the first metre.

Do not install external cladding such that it may remain in contact with standing water.

## NOTE

Greater clearance may be required in order to comply with termite protection provisions, see below for more information.

## Termite Protection

The NCC specifies the requirements for termite barriers. Where the exposed slab edge is used as part of the termite barrier system, a minimum of 75mm of the exposed slab edge must be visible to permit ready detection of termite entry.

## Fire Rated Walls

Hardie™ Oblique™ Cladding and Stria™ Cladding can be used as part of a fire rated wall when constructed with additional fire rated linings as specified in Hardie™ Fire and Acoustically Rated Design Manual and Construction of Fire and Acoustically Rated Walls Technical Specification or the Hardie™ Smart Boundary Wall System Design Guide. The length of fasteners must be increased for the additional linings.

## Moisture Management

It is the responsibility of designer or specifier to identify moisture related risks associated with any particular building design. Wall construction design must effectively manage moisture, accounting for both the interior and exterior environments of the building, particularly in buildings that have a higher risk of wind driven rain penetration or that are artificially heated or cooled.

In addition, all wall openings, penetrations, junctions, connections, window sills, heads and jambs must incorporate appropriate flashing and waterproofing. Materials, components and their installation that are used to manage moisture in framed wall construction must, at a minimum, comply with the requirements of relevant standards and the NCC.

## Weather Barrier

A suitable water control membrane must be installed under Hardie™ cladding products/ Hardie™ Wrap Weather Barrier in accordance with the AS/NZS 4200.2 'Pliable building membranes and underlays – Installation' and NCC requirements.

James Hardie has tested and certified the use of Hardie™ cladding products/ Hardie™ Wrap Weather Barrier for Climate Zones 2-8 within Australia. Hardie™ cladding products/ Hardie™ Wrap Weather Barrier is a Class 4 vapour permeable membrane that delivers a tripleshield of protection to help against external weather penetration, internal condensation management and external heat penetration through its saffeglare reflective layer.

If using an alternate product in lieu of Hardie™ cladding products/ Hardie™ Wrap Weather Barrier or the project is located in a hot, humid area (Climate Zone 1), the designer must ensure that the product is fit for purpose and it has the following classification in accordance with AS/NZS 4200.1:2017 'Pliable building membranes':

TABLE 1

Weather Barrier Classification		
Climate Zone	Water Control Classification	Vapour Control Category
2-8	Water Barrier	Vapour Permeable (Class 3 or 4)
1		Vapour Barrier (Class 1 or 2)

Soft compressible insulation installed between the front of the wall studs and directly behind the external cladding can cause installation issues and is thus not recommended.

## Flashing

All wall openings, penetrations, intersections, connections, window sills, heads and jambs must be flashed prior to cladding installation.

## FRAMING

### General

Hardie™ Oblique™ Cladding and Stria™ Cladding can be installed over a timber or steel frame and either direct fixed to frame or to Hardie™ Cavity Battens or timber battens. The general framing requirements for installation are given in Table 2.

TABLE 2

General Framing Requirements				
Type	Timber		Steel	
<b>Design</b>	Use of timber framing must be in accordance with AS 1684 and the framing manufacturer's specifications		Use of steel framing must be in accordance with NASH standard for Residential and Low-Rise Steel Framing Part 1: Design Criteria and the framing manufacturer's specifications.	
<b>Durability</b>	'Timber used for house construction must have the level of durability appropriate for the relevant climate and expected service life. Reference AS 1684.2 'Residential timber-framed construction'.		The steel framing must have the appropriate level of durability required to prevent corrosion, particularly in coastal areas.	
<b>Tolerances</b>	Ensure frame is square and work from a central datum line. A suggested maximum tolerance of between 3mm and 4mm in any 3000mm length of frame will give best results.			
<b>Thermal Break Requirement</b>	Not required.		For steel frames, the NCC Sections J3D6 and 13.2.5 Volumes 1 and 2 respectively, state for both residential and commercial buildings a thermal break such as Hardie™ Break with an R 0.2m2 K/W must be installed behind external cladding where the cladding and internal lining make direct contact with the same steel frame. Alternatively, vented cavity installation using minimum 70x350mm timber battens or off-stud Hardie™ Cavity Battens can be used in these applications.	
<b>BMT</b>	N/A.		Framing members must have a base metal thickness (BMT) between 0.55 to 1.6mm.	
<b>Orientation</b>	<b>Horizontal</b>			
<b>Type</b>	Direct Fix	Cavity Fix	Direct Fix	Cavity Fix
<b>Min. Stud Width</b>	When using the Stria™ Vertical Stop: -Double 45mm stud, or -Triple 35mm studs 35mm studs elsewhere.	35mm	32mm	32mm
<b>Min. Stud Depth</b>	70mm	70mm	64mm	64mm
<b>Min. Nogging Spacing</b>	1350mm	Refer to Table 5	1350mm	Refer to Table 5
<b>Battens</b>	N/A	Hardie™ Cavity Battens or min MGP10 70x35mm timber battens	N/A	Hardie™ Cavity Battens or min MGP10 70x35mm timber battens

Maximum stud, Hardie™ Cavity Batten and fastener spacing for Hardie™ Oblique™ Cladding and Stria™ Cladding for wind load classifications of AS 4055 'Wind Loads for Housing' are given in Table 3, 4 and 5.

Ensure framing joints are tight and all framing is fully loaded before Hardie™ Oblique™ Cladding and Stria™ Cladding is installed.

## FASTENERS

### General

All nails must be driven flush. **Before fixing to steel frame, ensure the aesthetic finish of Hardie™ Oblique™ Cladding and Stria™ Cladding when using Hardie™ Drive screws is of acceptable quality prior to installation, see Important Note 3 on page 2 of this guide.** For more information and advice, Ask James Hardie™ on 13 11 03.

### Fastener Durability (Including Coastal Areas)

Fasteners must have the appropriate level of durability and be fully compatible with all other materials required for the intended project. In areas within 1km of a coastal area, areas subject to salt spray and other corrosive environments, class 4 fasteners must be used.

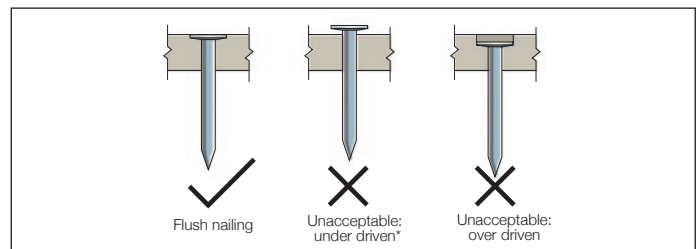


FIGURE 1 NAIL FASTENER DEPTH

\* Only when face fixing, fasteners can be under driven and tapped maximum 1mm below the surface of the board (Do not overdrive using gun nails). All fastener penetrations must be patched and sanded. Refer to the Finishing and Maintenance section on Page 15.

TABLE 3

Horizontal Stria™ Cladding Standard Profile and Hardie™ Oblique™ Cladding Fixing Options.							
Non-Cyclonic Wind	Cyclonic Wind	Fasteners Details			Fixing Figure	Max. Stud Spacing (mm)	
		Direct Fix	Cavity Fix	Configuration		General Areas of Walls	Within 1200mm of building edges
<b>Concealed Fixing Option</b>							
N1, N2	-	40 x 2.8mm Fibre Cement Nail	25 x 2.8mm Fibre Cement Nail	1 per board in underlap HAND NAILED	1	600	600 450 (For steel frame)
N3	C1	40 x 2.8mm Fibre Cement Nail	-	1 per board in underlap HAND NAILED	1	600	600 450 (For steel frame)
<b>Face Fixing Options</b>							
N1, N2, N3	C1	50mm ND or DA Brad Nail	32mm DA Brad Nail	2 per board-through face	2	600	600
N1, N2, N3	C1	50 x 2.8mm Fibre Cement Nail (Gun Nail)	-	1 per board-through face	2	600	600
N4	C2	50 x 2.8mm Fibre Cement Nail (Gun Nail)	-	1 per board-through face	2	600	450
N5, N6	C3, C4	50 x 2.8mm Fibre Cement Nail (Gun Nail)	-	2 per board-through face	2	450	300

TABLE 4

Horizontal Stria™ Cladding Wide Profile Fixing Options.							
Non-Cyclonic Wind	Cyclonic Wind	Fasteners Details			Fixing Figure	Max. Stud Spacing (mm)	
		Direct Fix	Cavity Fix	Configuration		General Areas of Walls	Within 1200mm of building edges
<b>Face Fixing Options</b>							
N1, N2, N3	C1	50mm ND or DA Brad Nail	32mm DA Brad Nail	2 per board-through face	2	600	600
N1, N2, N3	C1	40 x 2.8mm Fibre Cement Nail + (50mm ND or DA Brad Nail or 50 x 2.8mm Fibre Cement Nail (Gun Nail))	-	2 per board -1 in underlap, (Hand nailed) and 1 through face (Gun nail)	3	600	600
N4	C2	40 x 2.8mm Fibre Cement Nail + 50 x 2.8mm Fibre Cement Nail (Gun Nail)	-	2 per board -1 in underlap, (Hand nailed) and 1 through face (Gun nail)	3	600	450
N5, N6	C3, C4	50 x 2.8mm Fibre Cement Nail (Gun Nail)	-	3 per board-through face	2	450	300

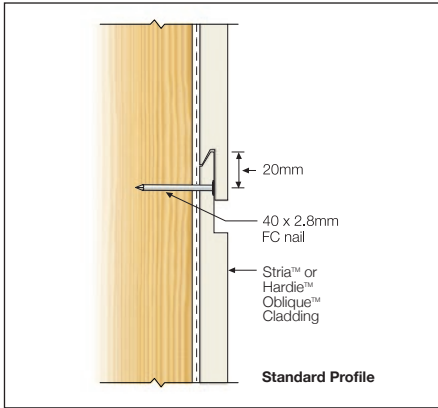
## NOTES: FIXING TOP AND BOTTOM ROWS OF BOARDS

- For N1, N2, N3 & C1 Bottom and top boards must be fixed with brad nails at 150mm centres or 300mm centres for other fixings.
- For N4, N5, N6, C3 & C4 top and bottom board must be fixed at 150mm centres.
- Fixing at every stud. Unless otherwise stated all values are for timber & steel.
- For both concealed and face fixing, use minimum class 3 fasteners.

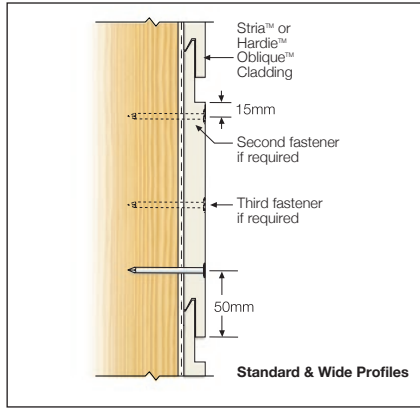
For steel framing thickness of 0.5mm – 1.6mm BMT use 41mm Hardie™ Drive screws. Hardie™ Break Thermal Strip must be installed behind the Hardie™ Oblique™ Cladding and Stria™ Cladding. Refer to the Hardie™ Break Thermal Strip Installation Guide for more information.

TABLE 5

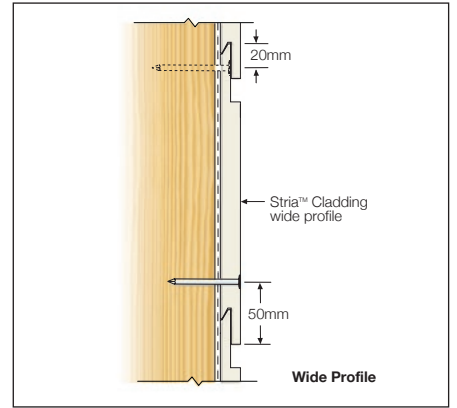
Maximum span and fastener specifications for Hardie™ Cavity Trim or Timber Batten for horizontal cladding installation.					
Batten Type	Dimensions (mm)	Timber Frame		Steel Frame	
		Max. Span (mm)	Fasteners	Max. Span (mm)	Fasteners
Hardie™ Cavity Battens	70 x 19	800	2.8 x 65mm long ring shank nail or 75 x 2.8mm D or round head galvanised smooth shank nail.	800	Two Hardie™ Drive Screws - Class 3 self-tapping wing-tipped screw for fastening to 0.5mm to 1.6mm BMT light gauge steel frames. 1000 per box. Product Codes: 305984 (loose) 305982 (collated).
Timber Battens	70 x 35	1350	Two 75 x 3.06mm D Head Class 3 nails per fixing.	800	Two 10-24 x 65mm Class 3 self drilling CSK-Head screws per fixing.



**FIGURE 1 CONCEALED FIXING FOR STANDARD PROFILE**

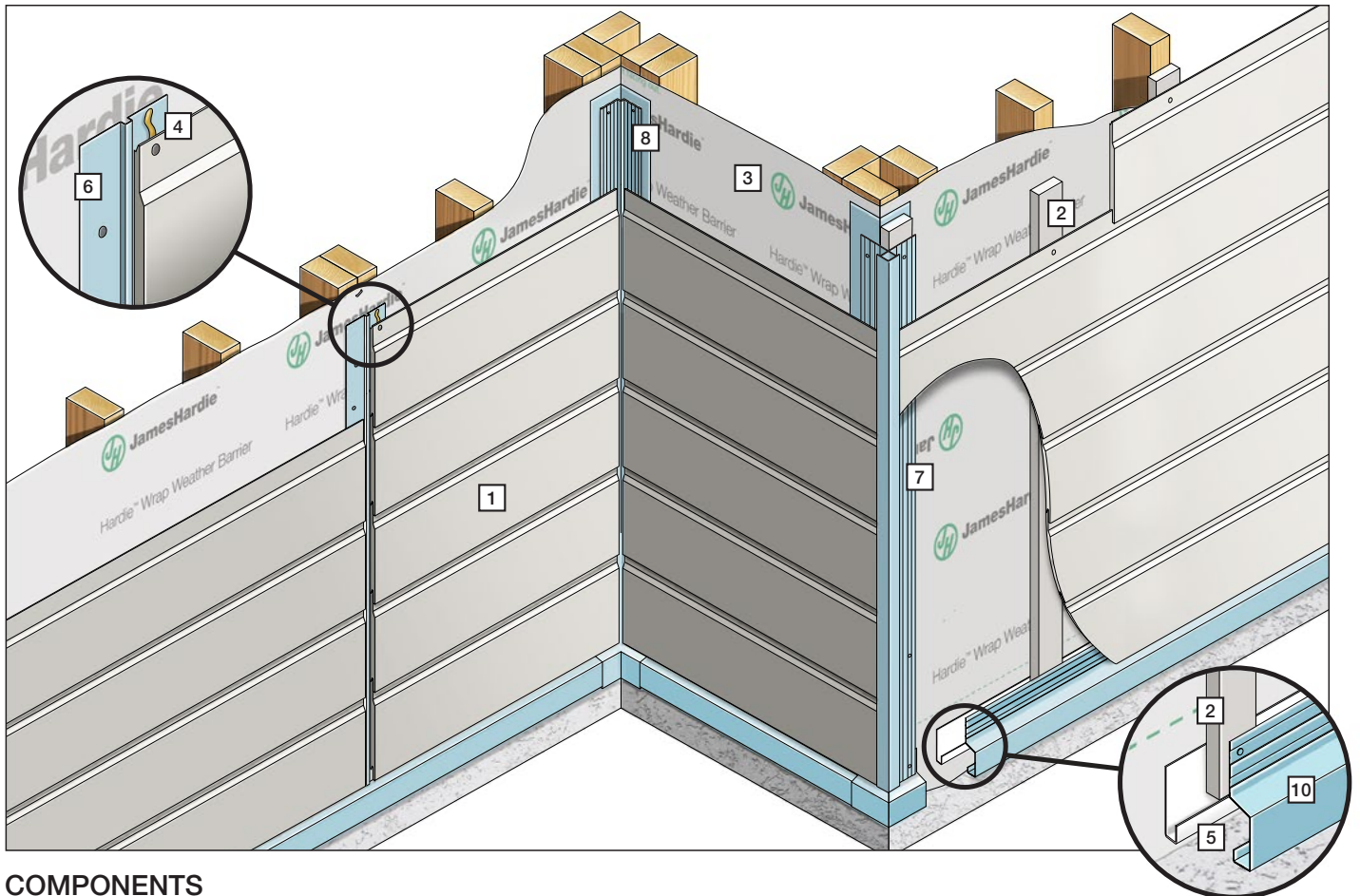


**FIGURE 2 FACE FIXING GUN & BRAD NAILS**

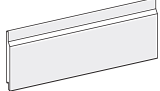



**FIGURE 3 FACE/CONCEALED FIXING FOR WIDE PROFILE**

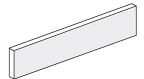


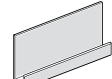
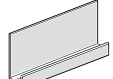
# 4 Products and Accessory Details



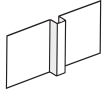
## COMPONENTS

1 Hardie™ Oblique™ Cladding		Product Code	Length (mm)	Width (mm)	Weight (kg/m <sup>2</sup> )*	Pack Size
 <p>Pre-sealed 14mm thick shiplap boards with unique square and angled groove edges to cast shadows and deliver highlights.</p>		405502	3000	200	18.4	75
		405503	3000	300	18.8	45
		405301	4200	200	18.4	75
		405303	4200	300	18.8	45
Stria™ Cladding		Product Code	Length (mm)	Width (mm)	Weight (kg/m <sup>2</sup> )*	Pack Size
 <p>Pre-sealed 14mm thick shiplap boards with deep and wide grooves to create strong, clean lines.</p>	Stria™ Standard	404063	4200	325	19.1	60
		405504	3000	325	19.1	60
	Stria™ Wide	404413	4200	405	19.4	40
		405505	3000	405	19.4	40


\* Includes the product weight only, taking into account effective coverage. This excludes fasteners, sealants and other accessories.

<b>2 Hardie™ Cavity Batten</b>  Fibre cement trim used to fix external cladding to steel or timber frame. Size: 70 x 19 x 3000mm. Pack Size: 96 Product Code: 405307	<b>3 Hardie™ Wrap Weather Barrier</b>  Water barrier and vapour permeable membrane. Unit size: 2.75 x 30m. Pack Size: 1 Each. Product Code: 305664 Coverage: 85.5m <sup>2</sup> per roll	<b>4 Hardie™ Joint Sealant</b>  General purpose polyurethane exterior grade joint sealant. Pack Size: 20/Box. Product Code: 305534 300ml Cartridge Product Code: 305672 600ml Sausage Coverage: 2.67m <sup>2</sup> /100ml (5mm dia bead)	<b>5 Hardie™ 18mm PVC Cavity Vent Strip</b>  A perforated PVC extrusion used at the bottom of walls behind cladding. Pack Size: 25. Product Code: 305555	<b>5 Hardie™ 35mm PVC Cavity Vent Strip</b>  A 3000mm long perforated PVC extrusion installed at the base of the cladding wall system to provide drainage, ventilation and vermin proofing. Pack Size: 25. Product Code: 306253
--	---	---	--	--

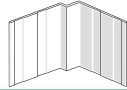
### Vertical Flashing


<b>6 Stria™ Stop</b>  For use with Stria™ and Oblique™ Cladding behind boards at vertical joints Product Code: 305547 T flashing 3000mm (5/pack) Coverage: Length of horizontal joints / 3000mm
---

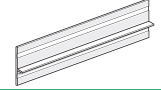
### External Corner






<b>7 Hardie™ 14mm Aluminium External Box Corner</b>  A ready to paint aluminium extrusion. 3000mm long. Pack Size: 5 Product Code: 305519 Coverage: Height of wall x no. of external corners / 3000mm
---

### Internal Corner Options

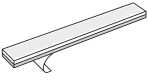




<b>8 Hardie™ 14mm Aluminium Internal Corner</b>  A ready to paint aluminium extrusion. 3000mm long. Pack Size: 5. Product Code: 305518 Coverage: Height of wall x no. of external corners / 3000mm
--

<b>8 Hardie™ 75mm Corner Flashing</b>  Manufactured using COLORBOND® steel, used behind cladding at internal and external corners. 75 x 75mm. Pack Size: 5. Product Code: 305564 Coverage: Height of clad walls x no. of corners / 3000mm
--

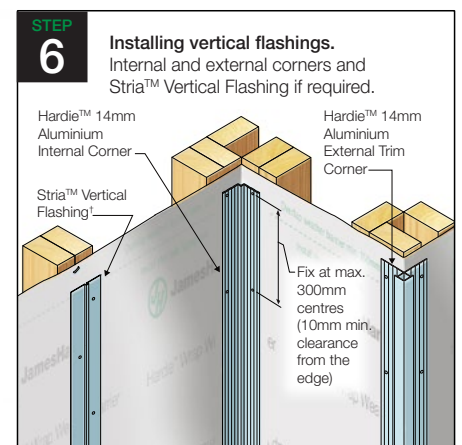
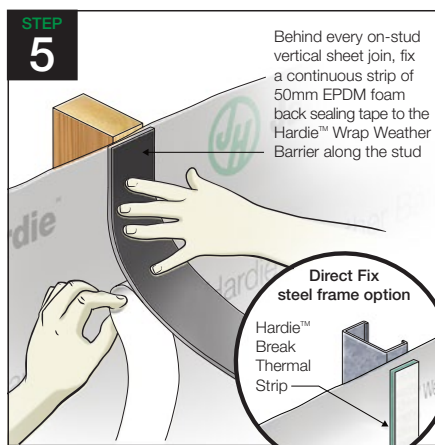
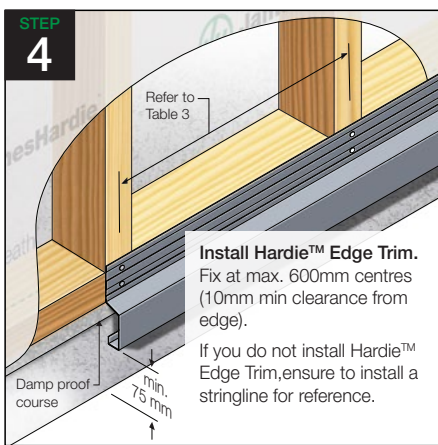
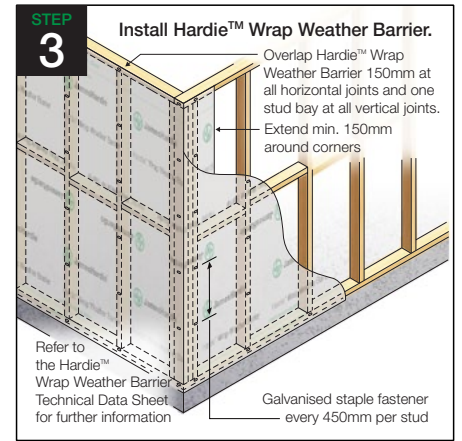
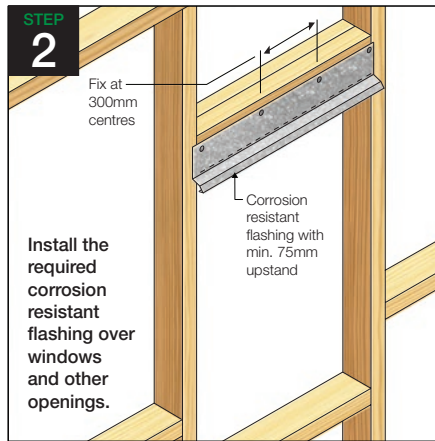
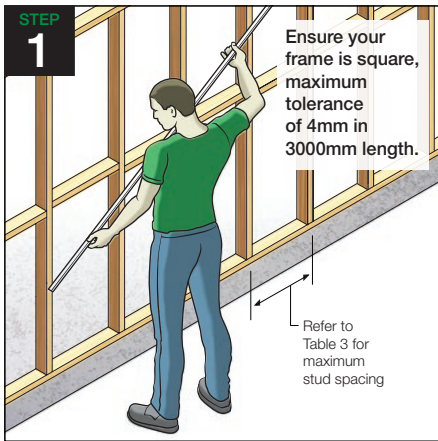
<b>9 Hardie™ Trimline Flashing</b>  To be used at horizontal joints (vertical cladding) or vertical butt joints (Horizontal cladding). (5/pack) Product Code: 306128. 3000mm Coverage: Length of horizontal joints / 3000mm
--

<b>10 Hardie™ Edge Base Trim</b>	<b>10 Hardie™ Edge Base Trim Jointer</b>	<b>10 Hardie™ Edge Internal Corner</b>	<b>10 Hardie™ Edge External Corner</b>	<b>11 Hardie™ Foam Back Sealing Tape</b>
				
<p>Powder coated aluminium extrusion used at slab edges. Pack Size: 25 units. Product Code: 305911</p>	<p>Powder coated aluminium extrusion used with Hardie™ Edge Base Trim. Pack Size: 12 units. Product Code: 305912</p>	<p>Powder coated aluminium extrusion used with Hardie™ Edge Base Trim at internal corner junctions. Pack Size: 4 units. Product Code: 305913</p>	<p>Powder coated aluminium extrusion used with Hardie™ Edge Base Trim at external corner junctions. Pack Size: 4 units. Product Code: 305914</p>	<p>Installed under sheet vertical joints to improve water tightness. 50mm wide 25mtr long roll. Pack Size: Each Product Code: 304560</p>

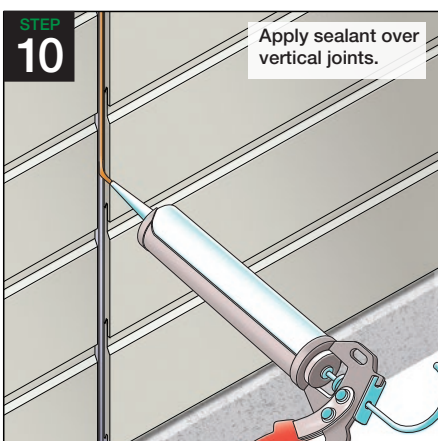
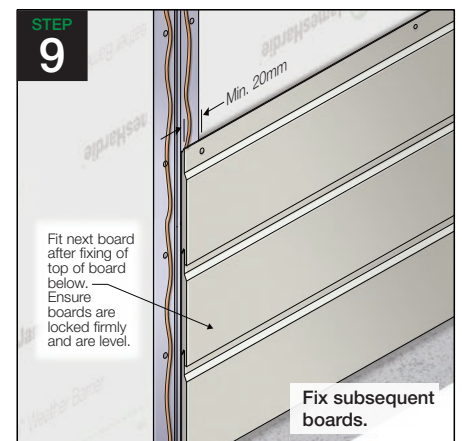
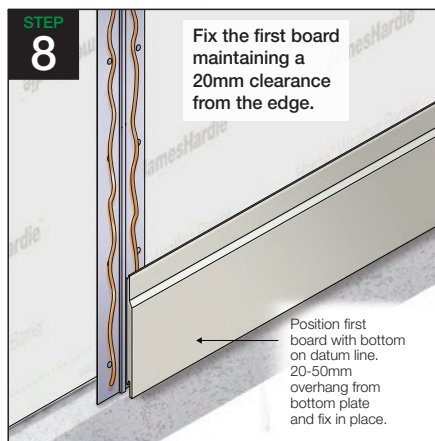
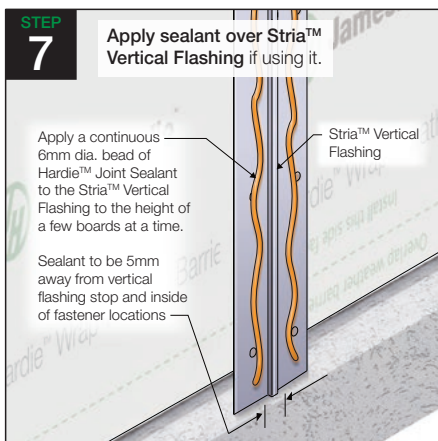
### Tools

<b>12 Hardie™ Break Thermal Strip</b>	<b>Hardie™ Blade Saw Blade 185mm Diameter</b>	<b>Dust-Reducing Saw with M class or higher vacuum Extraction</b>	<b>Drop Saw*</b>	<b>Gun Nails and Nailers</b>
				
<p>A hard, dual layer density self-adhesive strip, for quick installation. The thermal strip is installed directly over a vapour permeable membrane and framing members. Pack Size: 45 units Product Code: 305612</p>	<p>Poly-diamond blade for Hardie™ fibre cement. Product Code: 300660 Pack Size: 1 each.</p>	<p>Dust reducing saw with a Hardie™ Blade saw blade. E.g. Makita 5057KB / Hitachi C7YA.</p>	<p>Drop saw with an aluminium blade. *Not to be used for cutting Hardie™ Oblique™ Cladding or Stria™ Cladding.</p>	<p>Refer to fastener section  Suitable gun nails and nailers for face fixing to timber framing only. Minimum nail length of 50mm is required. Minimum class 3.</p>

# 5 Cladding Installation Steps\* - Direct Fix

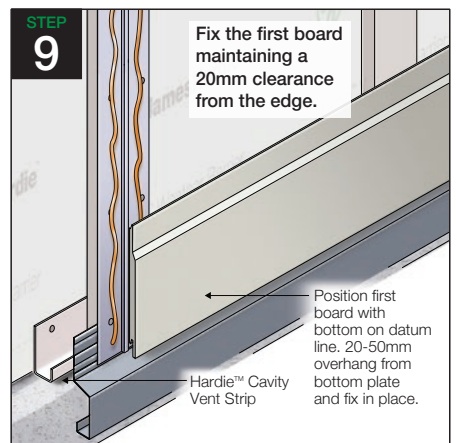
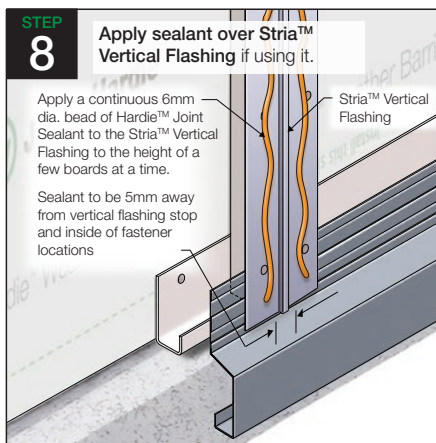
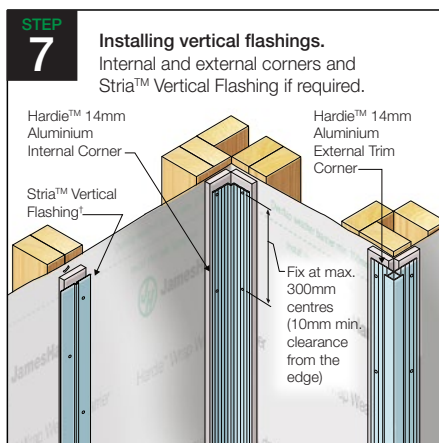
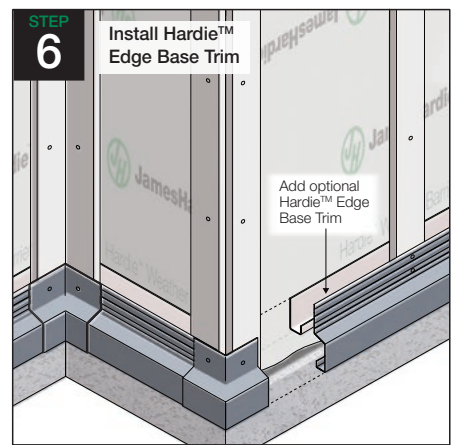
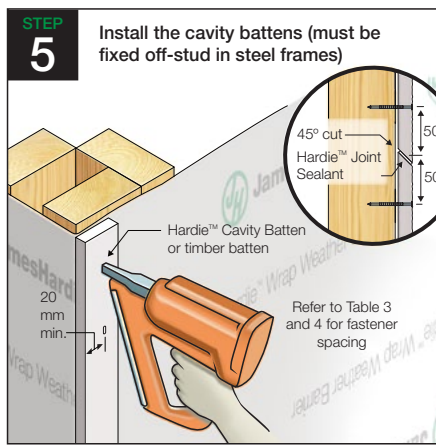
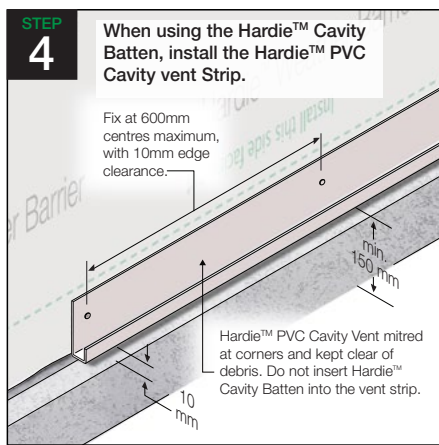
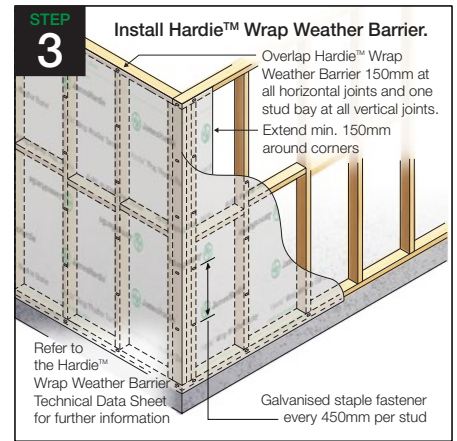
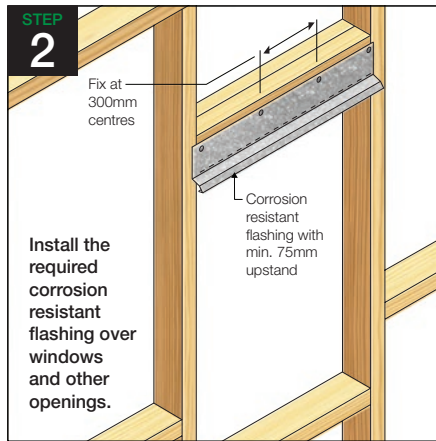


† Needed where a vertical express joint is required.

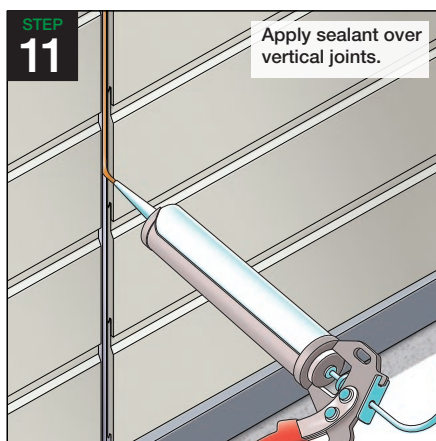
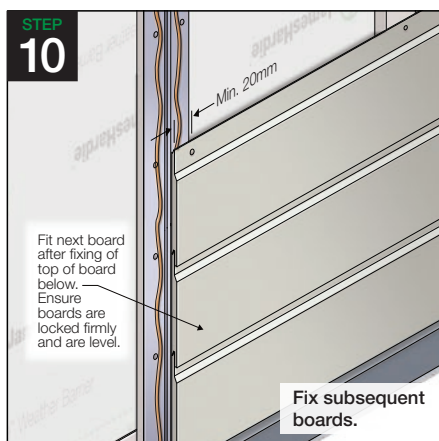


\*This is an overview of the installation process only. It is not a substitute for reviewing this document in its entirety prior to installation.

# 6 Cladding Installation Steps\* - Cavity Fix



† Needed where a vertical express joint is required.



\*This is an overview of the installation process only. It is not a substitute for reviewing this document in its entirety prior to installation.

# 7 Construction Details - Direct Fix

## JUNCTION DETAILS

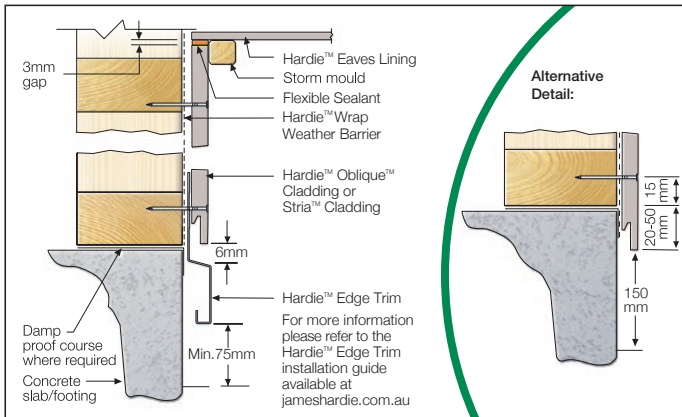


FIGURE 1 SLAB/EAVE JUNCTION DETAIL

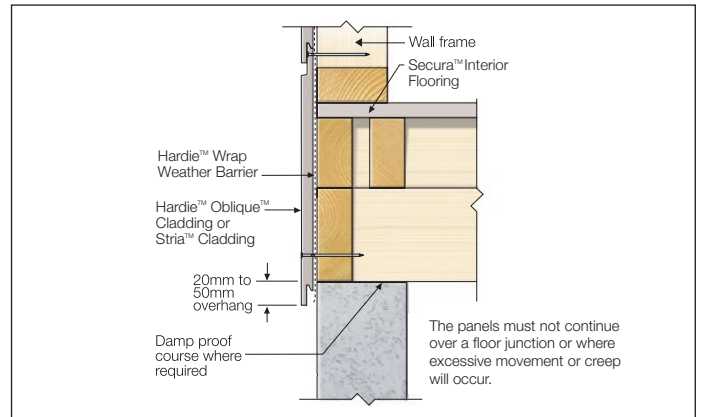


FIGURE 2 LOWER FLOOR JUNCTION

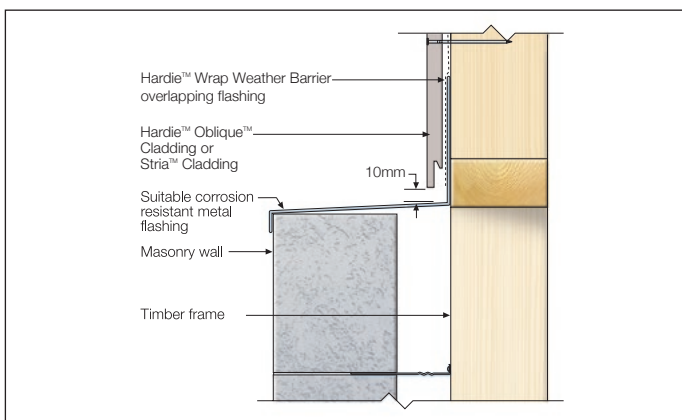


FIGURE 3 HORIZONTAL JUNCTION

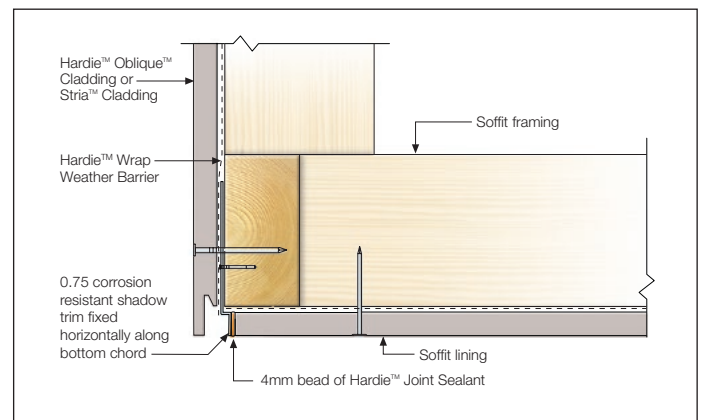


FIGURE 4 FACADE/SOFFIT JUNCTION

## INTERNAL CORNER DETAIL

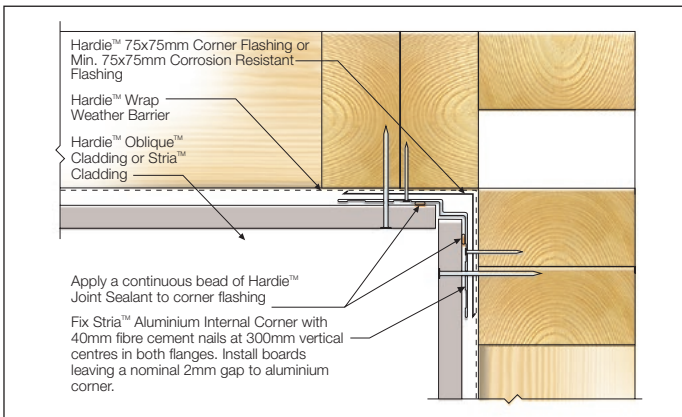


FIGURE 5 INTERNAL CORNER

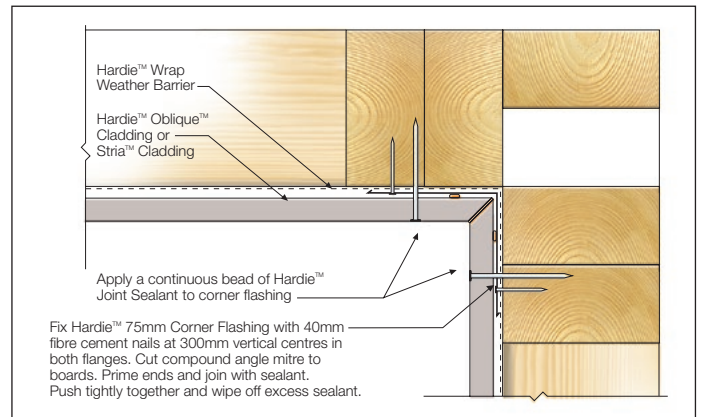


FIGURE 6 INTERNAL MITRE CORNER

## EXTERNAL CORNER DETAILS

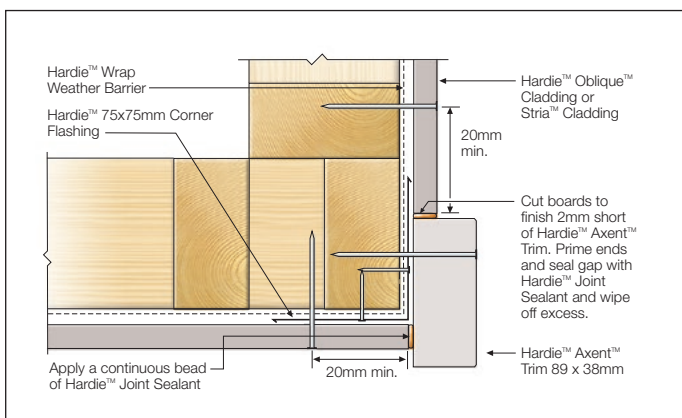


FIGURE 7 EXTERNAL TRIM CORNER

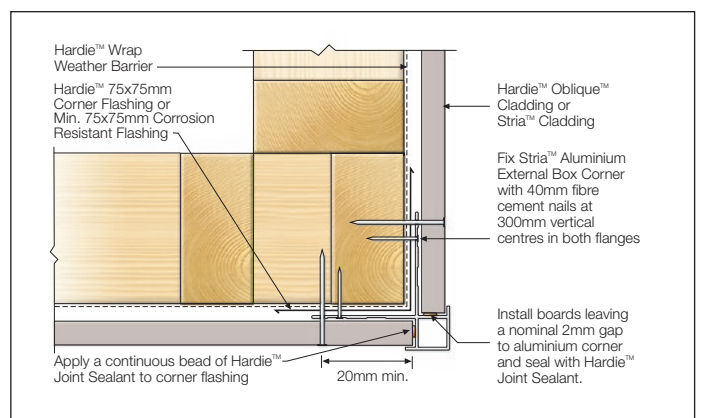


FIGURE 8 EXTERNAL BOX CORNER

## JOINT DETAILS

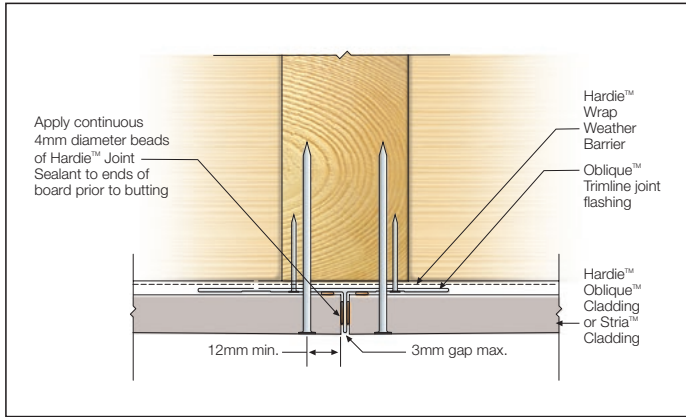


FIGURE 9 VERTICAL JOINT DETAIL

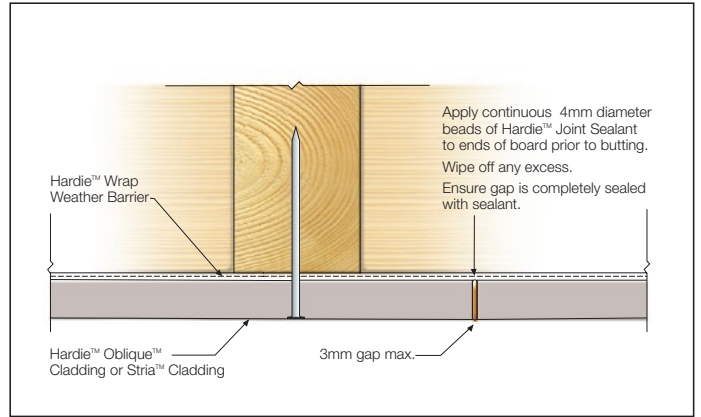


FIGURE 10 OFF-STUD JOINT

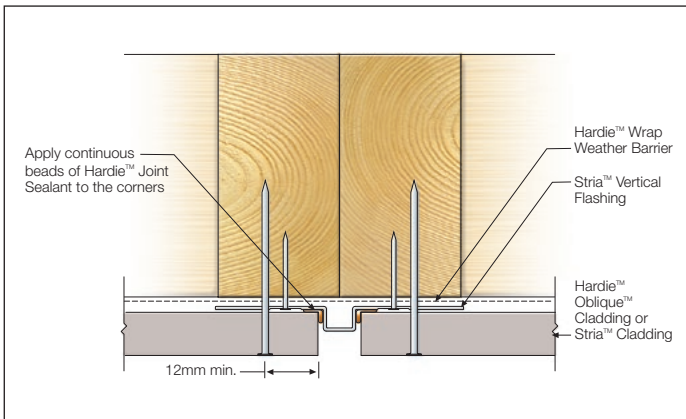


FIGURE 11 VERTICAL JOINT USING STRIA™ VERTICAL FLASHING STOP

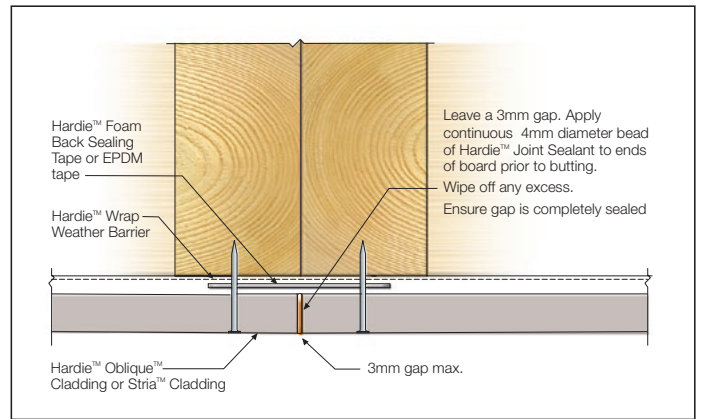


FIGURE 12 HARDIE™ FOAM BACK SEALING TAPE DETAIL

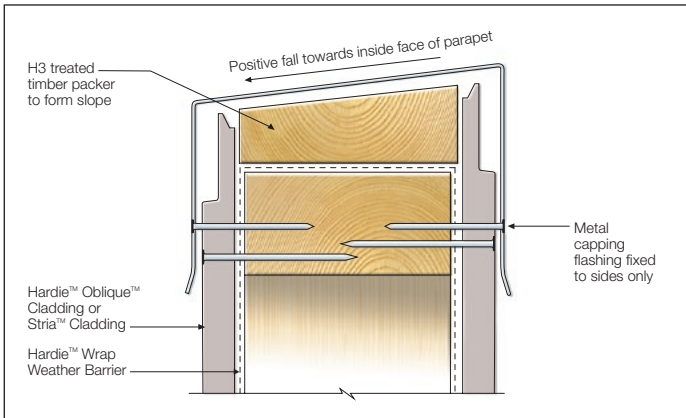


FIGURE 13 PARAPET DETAIL

## WINDOW DETAILS

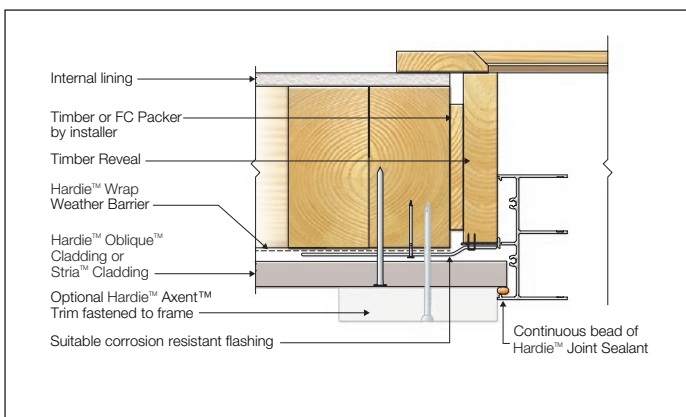


FIGURE 14 WINDOW JAMB - TRIM

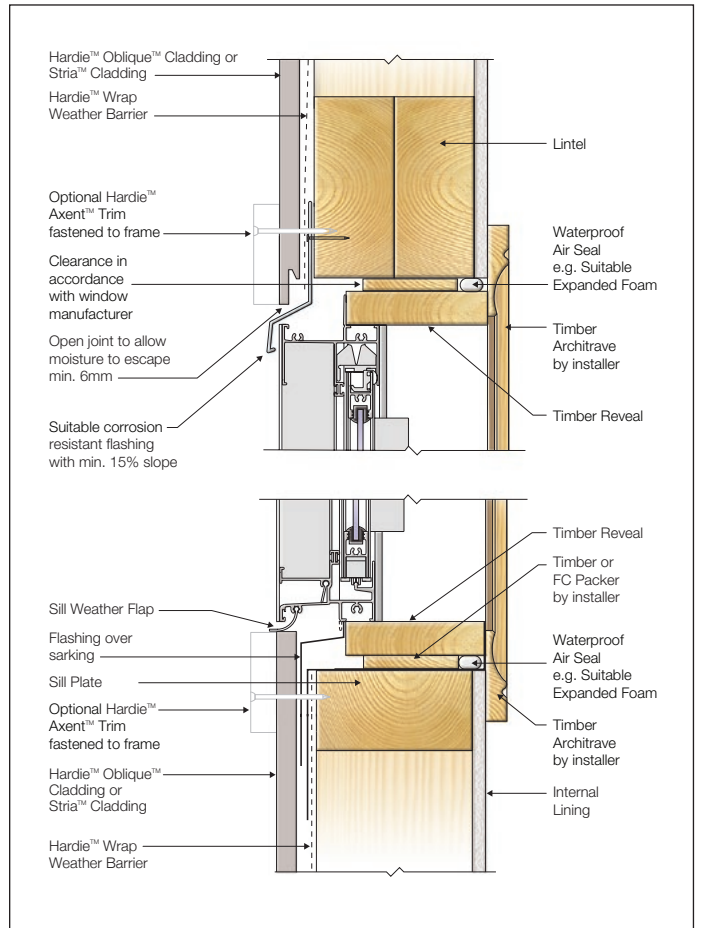


FIGURE 15 WINDOW HEAD AND SILL - TRIM

# 8 Construction Details - Cavity Fix

## JUNCTION DETAILS

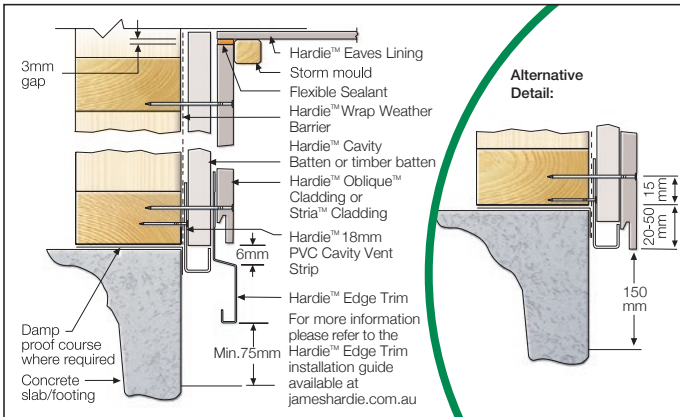


FIGURE 16 SLAB/EAVE JUNCTION DETAIL

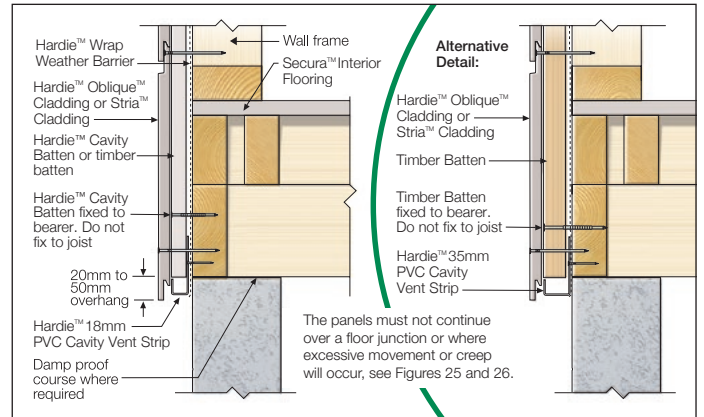


FIGURE 17 LOWER FLOOR JUNCTION

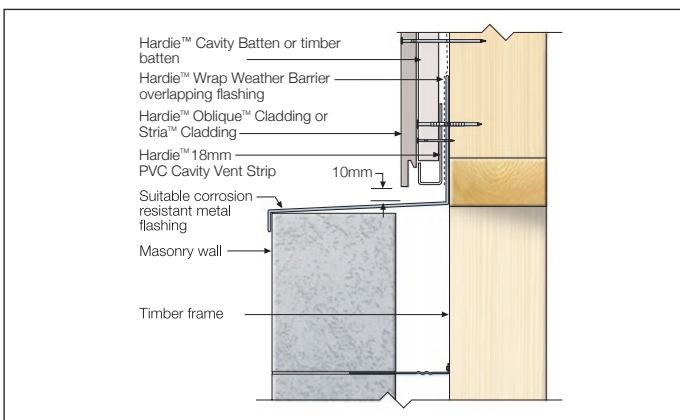


FIGURE 18 HORIZONTAL JUNCTION

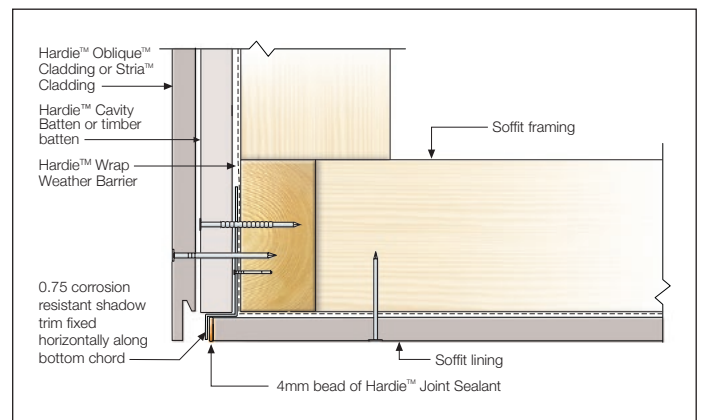


FIGURE 19 FACADE/SOFFT JUNCTION - CAVITY FIX

## INTERNAL CORNER DETAIL

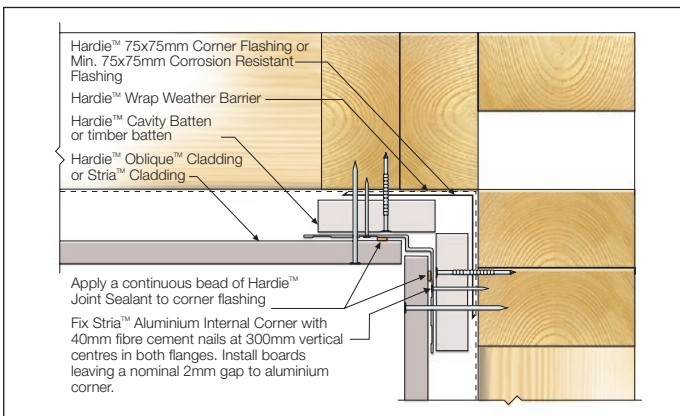


FIGURE 20 INTERNAL CORNER

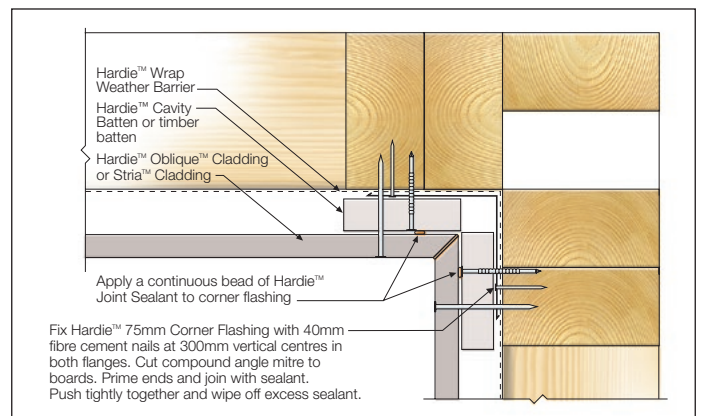


FIGURE 21 INTERNAL MITRE CORNER

## EXTERNAL CORNER DETAILS

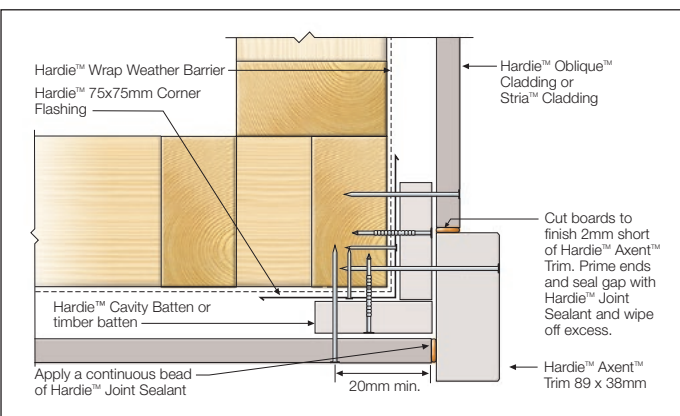


FIGURE 22 EXTERNAL TRIM CORNER

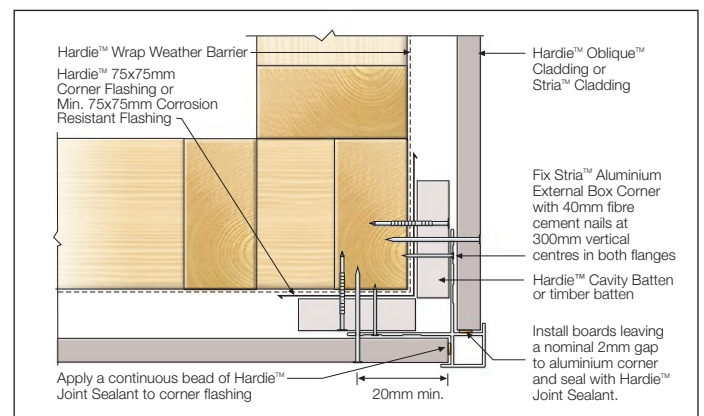


FIGURE 23 EXTERNAL BOX CORNER

## JOINT DETAILS

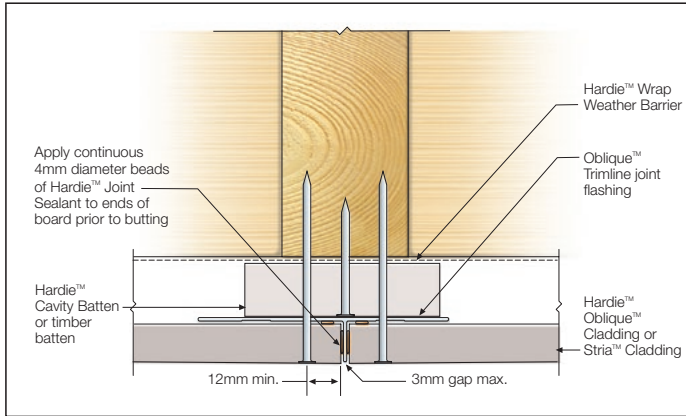


FIGURE 24 VERTICAL JOINT DETAIL

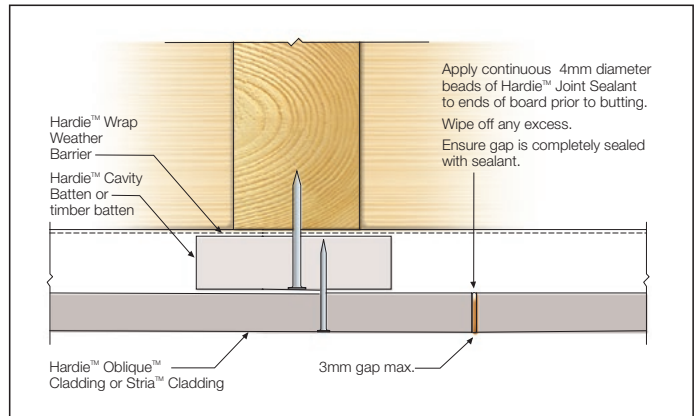


FIGURE 25 OFF-STUD JOINT

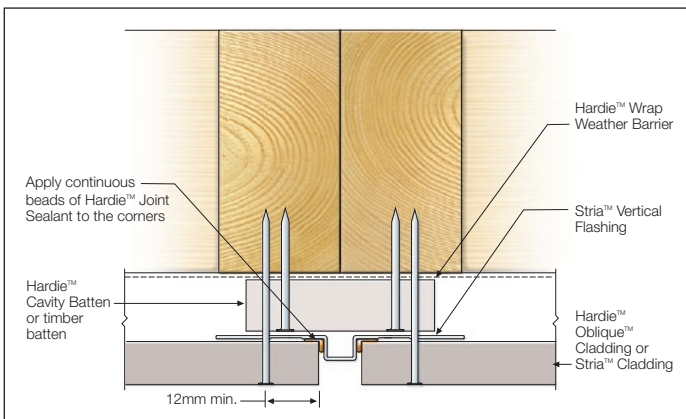


FIGURE 26 VERTICAL JOINT USING STRIA™ VERTICAL FLASHING STOP

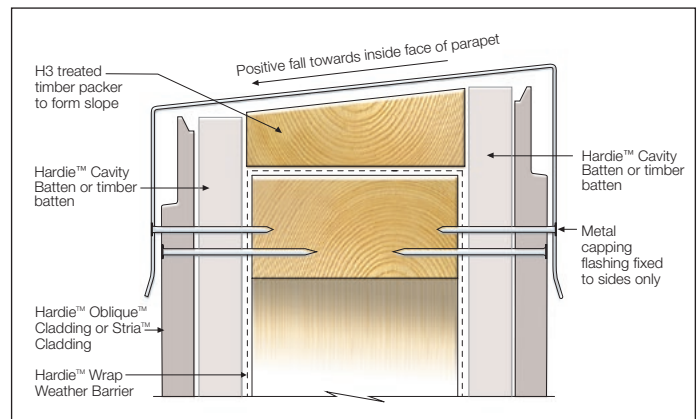


FIGURE 27 PARAPET DETAIL

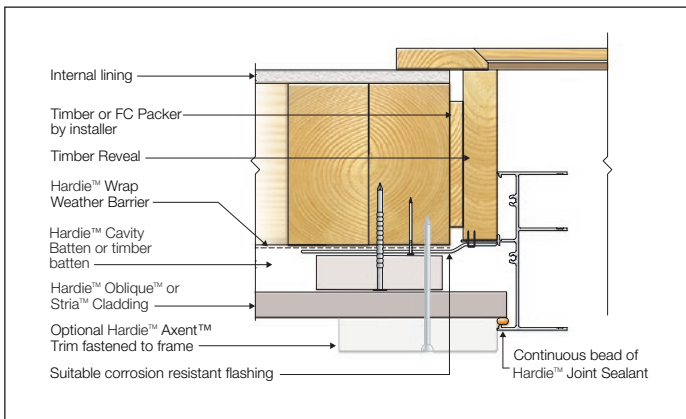


FIGURE 28 WINDOW JAMB - TRIM

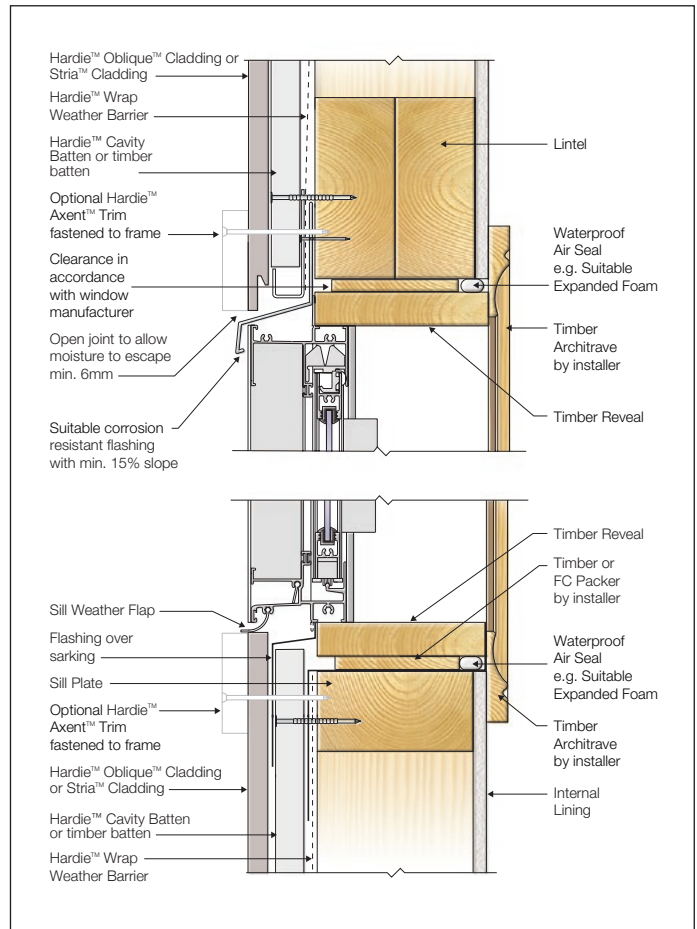


FIGURE 29 WINDOW HEAD AND SILL - TRIM

# 9 Finishes and Maintenance

## SURFACE PREPARATION

Ensure the surface is dry, clean and any overdriven nails are patched in accordance with this specification.

Any slightly overdriven brad nails (1mm max.) may be repaired using a suitable external grade filling agent. All patches must be sanded and primed before applying the paint.

### Sealants

James Hardie recommends the use of Hardie™ Joint Sealant, which is a paintable polyurethane sealant. If using an alternative sealant, it must be a quality polyurethane sealant compatible with fibre cement and the specified paint system if coated. Please refer to the manufacturer's instructions for further information.

## PAINTING

Panels must be finished within 3 months of being fixed with the recommended coating. In areas within 1km of a coastal area or corrosive environment, panels must be coated within 7 days of fixing sheets to minimise contamination build up on the heads of the fasteners.

## MAINTENANCE

The extent and nature of maintenance will depend on the geographical location and exposure of the building. As a guide, it is recommended that basic normal maintenance tasks shall include but not be limited to:

- Washing down exterior surfaces every 6-12 months\*
- Periodic inspections should be made to ensure fasteners are adequately securing the sheets to framing.
- Re-applying of exterior protective finishes\*
- Maintaining the exterior envelope and connections including joints, penetrations, flashings and sealants that may provide a means of moisture entry beyond the exterior cladding.
- Cleaning out gutters, blocked pipes and overflows as required.
- Pruning back vegetation that is close to or touching the building.

\*Refer to your paint manufacturer for washing down and recoating requirements related to paint performance.

# 10 Product Information

## PRODUCT INFORMATION

### Material

The basic composition of Hardie™ building products is Portland cement, ground sand, cellulose fibre, water and proprietary additives.

Hardie™ building products are manufactured to AS/NZS 2908.2 'Cellulose-Cement Products-Flat Sheet'. These are also compliant with equivalent standard ISO 8336 'Fibre-cement flat sheets - Product specification and test methods'. For product classification refer to the relevant Physical Properties Data Sheet.

### Durability

#### Resistance to Moisture/Rotting

Hardie™ Oblique™ Cladding and Stria™ Cladding have demonstrated resistance to permanent moisture induced deterioration (rotting) by passing the following tests in accordance with AS/NZS 2908.2:

- Water permeability (Clause 8.2.2)
- Heat rain (Clause 6.5)
- Warm water (Clause 8.2.4)
- Soak dry (Clause 8.2.5)

#### Resistance to fire

The Hardie™ Oblique™ Cladding and Stria™ Cladding are suitable where non-combustible materials are required in accordance with C2D10 and H3D2 of the National Construction Code (NCC) Vol 1 and 2 respectively.

Hardie™ building products have been tested by CSIRO in accordance with AS/NZS 3837 and are classified as conforming to Group 1 material (highest and best result possible), with an average specific extinction area far lower than the permissible 250m<sup>2</sup>/kg, as referenced in Specification C2D11(1) of the NCC 2022.

#### Resistance to Termite Attack

Based on testing completed by CSIRO Division of Forest Products and Ensis Australia, Hardie™ building products have demonstrated resistance to termite attack.

### Alpine Regions

In regions subject to freeze/thaw conditions, all James Hardie fibre cement external cladding must be installed and painted in the warmer months of the year where the temperature does not create freeze and thaw conditions or paint issues. The cladding must be painted immediately after installation. In addition, fibre cement cladding must not be in direct contact with snow and/or ice build up for extended periods, e.g. external walls in alpine regions subject to snow drifts over winter.

Furthermore, a reputable paint manufacturer must be consulted in regards to a suitable product, specifications and warranty. The paint application must not be carried out if the air temperature or the substrate temperature is outside the paint manufacturer's recommendation including the specified drying temperature range

Hardie™ external cladding products are tested for resistance to frost in accordance with AS/NZS 2908.2 Clause 8.2.3.

# 11 Site Installation Checklist

## USING THE CHECKLIST

Highlighting some key features of the Hardie™ Oblique™ Cladding and Stria™ Cladding Horizontal Installation Guide, this checklist has been created to assist you in the installation of Hardie™ Oblique™ Cladding and Stria™ Cladding. Ensure all requirements of each stage are completed and marked as such before progressing to the next stage.

**IMPORTANT:** This checklist is not an exhaustive list of all compliance and construction requirements and it must only be used as a supplement to, and not a substitute for, compliance with the entirety of the Hardie™ Oblique™ Cladding and Stria™ Cladding Horizontal Installation Guide current at the time of installation. Please note, this checklist is for your own use, it is not to be submitted to James Hardie, and completion of this checklist does not evidence, and will not be accepted as being evidence of compliance with the Hardie™ Oblique™ Cladding and Stria™ Cladding Horizontal Installation Guide.

Project location: \_\_\_\_\_ Installer: \_\_\_\_\_

Project Wind Category: N1 & N2 | N3/C1 | N4/C2 | N5/C3 | N6/C4 Fixing method: Face Fixing | Concealed Fixing

Frame Material: Timber | Steel | Masonry Batten Spacing (mm): 900 | 600 | 450 Stud Spacing (mm): 600 | 450 | 300 Board Fastener: \_\_\_\_\_

Batten Fastener: \_\_\_\_\_ No. of Board Fasteners: 1 | 2 | 3 Corrosive environment: Yes - Less than 1km to coastal area | Yes - Other | No

Stage	Diagram	Requirement	Reference	Completed	Comments
Planning		<b>Safe Working Practices</b> Ensure you understand how to work safely with Fibre Cement.	Page 3	<input type="checkbox"/> YES <input type="checkbox"/> NO	
		<b>Board sizes</b> Ensure optimal board length is chosen based on the wall dimensions.	Page 7 - Item 1	<input type="checkbox"/> YES <input type="checkbox"/> NO	
		<b>Vertical joint location</b> Plan the location of vertical joints to align with the house design.	Page 9 - Step 6 Page 10 - Step 7	<input type="checkbox"/> YES <input type="checkbox"/> NO	
		<b>Window/door reveal sizing</b> Verify overall frame thickness compared to window reveal sizing.	Page 12 - Fig 14 and 15 Page 14 - Fig 28 and 29	<input type="checkbox"/> YES <input type="checkbox"/> NO	
		<b>Customized flashing</b> Determine the geometry of flashings over openings.	Page 9 and 10 - Step 2	<input type="checkbox"/> YES <input type="checkbox"/> NO	
Framing Preparation		<b>Stud spacing</b> Verify the maximum stud spacing based on the projects wind category.	Page 5 - Table 3 and 4	<input type="checkbox"/> YES <input type="checkbox"/> NO	
		<b>Noggin Spacing</b> Ensure the noggins are within the maximum allowed.	Page 4 - Table 2	<input type="checkbox"/> YES <input type="checkbox"/> NO	
		<b>Frame straightness</b> Ensure the frame is square.	Page 9 and 10 - Step 1	<input type="checkbox"/> YES <input type="checkbox"/> NO	
		<b>Flashing above window and openings</b> All required flashings are installed over openings.	Page 9 and 10 - Step 2	<input type="checkbox"/> YES <input type="checkbox"/> NO	
		<b>Ground Clearance</b> Frame installed considering minimum distance to the ground.	Page 3 - Ground clearances	<input type="checkbox"/> YES <input type="checkbox"/> NO	
Pre-Cladding		<b>Windows/doors installed</b> Windows and doors installed to manufacturers specification.	Page 12 - Fig 14 and 15 Page 14 - Fig 28 and 29	<input type="checkbox"/> YES <input type="checkbox"/> NO	
		<b>Hardie™ Wrap Weather Barrier</b> Installed in accordance with the product's installation guide.	Page 9 - Step 4 Page 10 - Step 3	<input type="checkbox"/> YES <input type="checkbox"/> NO	
		<b>EPDM or Hardie™ Thermal Break over studs (direct fix only)</b> Applied over studs	Page 9 - Step 5	<input type="checkbox"/> YES <input type="checkbox"/> NO	
		<b>Cavity trims or timber battens (cavity fix only)</b> Vertical battens installed.	Page 10 - Step 5	<input type="checkbox"/> YES <input type="checkbox"/> NO	
		<b>Corner installation</b> Internal and external corner accessories installed.	Page 9 - Step 6 Page 10 - Step 7	<input type="checkbox"/> YES <input type="checkbox"/> NO	
		<b>Vertical Flashing</b> Vertical flashing installed to manufacturers specifications.	Page 9 - Step 7 Page 10 - Step 8	<input type="checkbox"/> YES <input type="checkbox"/> NO	
		<b>Horizontal Trim installation</b> Base trims and flashing installed to manufacturers specifications.	Page 11 - Fig 1 Page 13 - Fig16	<input type="checkbox"/> YES <input type="checkbox"/> NO	

# 11 Site Installation Checklist cont.

Stage	Diagram	Requirement	Reference	Completed	Comments
Cladding Installation		<b>Sealant applied over vertical flashing</b> Hardie™ Joint Sealant applied over vertical battens.	Page 9 - Step 7 Page 10 - Step 8	<input type="checkbox"/> YES <input type="checkbox"/> NO	
		<b>Fastener Spacing</b> Fastener spacing within the maximum based on wind category.	Page 5 - Table 3 and 4	<input type="checkbox"/> YES <input type="checkbox"/> NO	
		<b>Edge clearance</b> Fasteners within the maximum distance from panel edges.	Page 9 - Step 8 and 9 Page 10 - Step 9 and 10	<input type="checkbox"/> YES <input type="checkbox"/> NO	
		<b>Sealant over vertical joints</b> All vertical joints sealed with Hardie™ Joint Sealant.	Page 9 - Step 10 Page 10 - Step 11	<input type="checkbox"/> YES <input type="checkbox"/> NO	
		<b>Sealant behind corners</b> All corners sealed with Hardie™ Joint Sealant.	Page 11 - Fig 5 - 8 Page 13 - Fig 20 to 23	<input type="checkbox"/> YES <input type="checkbox"/> NO	
Painting		<b>Surface imperfections repaired</b> All imperfections and over-driven nails are fixed.	Page 15 - Section 10	<input type="checkbox"/> YES <input type="checkbox"/> NO	
		<b>Wall painted</b> Wall painted within the maximum recommended time.	Page 15 - Section 10	<input type="checkbox"/> YES <input type="checkbox"/> NO	

# Notes





**For information and advice  
call 13 11 03 | [jameshardie.com.au](https://jameshardie.com.au)**

**Australia May 2024**



© 2024 James Hardie Australia Pty Ltd ABN 12 084 635 558  
™ and © denote a trademark or registered mark owned by James Hardie Technology Limited.  
Codemark®, Colorbond®, Hitachi, Makita® and Hilti are trademarks or registered trademarks of  
their respective owners and are not owned by James Hardie Technology Limited.