



Alpha

TUFFBOX PRO

PRODUCT CATALOGUE



CONTENTS



ORIGINAL TUFFBOX VS. TUFFBOX PRO

2 - 3



COBALT Series

DRILL SET

6



STAINLESS Plus

DRILL SET

7



GOLD Series

DRILL SET

8 - 9



BLACK Series

DRILL SET

10



SILVER Series

DRILL SET

11

CONTENTS



REDUCED Shank

DRILL SET

12



THUNDER MAX

STEP DRILL SET

13



IMPACT

THIN METAL HOLESAW SET

14 - 15



Carbon XTRA

DRILL & TAP SET

16



Carbon XTRA

DRILL, TAP & DIE SET

17



REO HEAD

SDS DRILL SET

18

Alpha

GOLD SERIES TUFFBOX

METRIC AND IMPERIAL SETS



ALPHA GOLD SERIES = 30% MORE HOLES*



TITANIUM NITRIDE COATING REDUCES HEAT AND INCREASES LUBRICITY FOR EXTENDED LIFE

FULLY GROUND PRECISION TEMPERED M2 HSS INCREASES DRILL LIFE

135° SPLIT POINT CUTS FASTER AND REDUCES WANDERING

TOUGH ABS PLASTIC

RUGGED RUBBER GRIPS

STRONG LOCKING CATCH

SUPPLIED WITH SECURITY TAB TO STOP PILFERING

FEEDS & SPEEDS CHART INSIDE EVERY DRILL SET



*30% MORE HOLES THAN OTHER LEADING BRANDS OF JOBBER DRILLS

RELEASED 2011

NOW TUFFER...

Alpha

TUFFBOX PRO

ALPHA'S LATEST INNOVATION

IT'S NOT JUST A TOOL BOX



- <<< STRONG HINGES ALLOW TOOL BITS TO STAND WHILST WORKING
- <<< COMPACT CASE FOR EASY TRANSPORTATION & SUSTAINABILITY
- <<< STURDY LATCH TO SECURE CONTENTS ON THE WORKSITE
- <<< BOLD COLOURED CASE FOR EASY LOCATION
- <<< BRAND NEW 26 PIECE SET WITH SITE READY FAVOURITES
- <<<< MORE DRILL RANGES AVAILABLE IN CONVENIENT SETS



COLOUR-CODED CASES FOR EASY DIFFERENTIATING BETWEEN METRIC & IMPERIAL

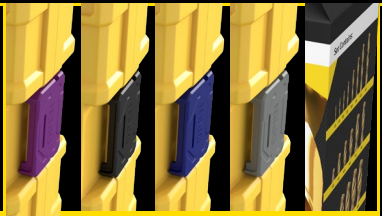

COLOUR-CODED LATCHES TO DISTINGUISH BETWEEN DIFFERENT SERIES



ECO-FRIENDLY & REUSABLE PACKAGING & RETAIL MERCHANDISING OPTIONS

25
PCE

29
PCE

COBALT Series Jobber Drills

**HEAVY
DUTY**

Ideal for
drilling
stainless
steel & high
tensile steel

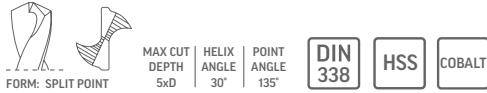

Ideal for: hard steel, cast iron & stainless steel

- 135° split point reduces wandering
- Fully ground HSS Cobalt raw material for extended life

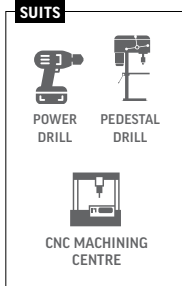
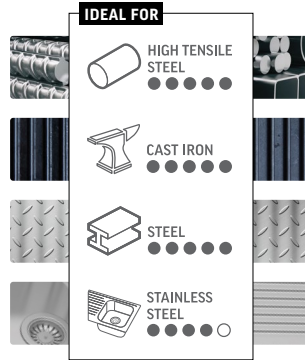
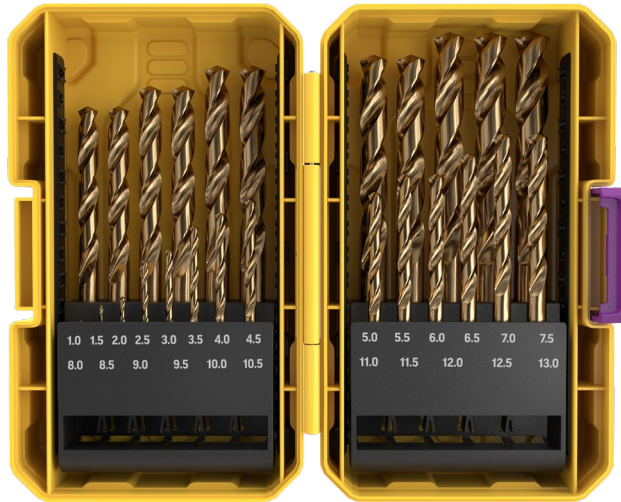

25 PCE Metric

Sizes: 1.0, 1.5, 2.0, 2.5, 3.0, 3.5, 4.0, 4.5, 5.0, 5.5, 6.0, 6.5, 7.0, 7.5, 8.0, 8.5, 9.0, 9.5, 10.0, 10.5, 11.0, 12.0, 12.5 & 13.0mm

CODE: SM25COTP

29 PCE Imperial

Sizes: 1/16", 5/64", 3/32", 7/64", 1/8", 9/64", 5/32", 11/64", 3/16", 13/64", 7/32", 15/64", 1/4", 17/64", 9/32", 19/64", 5/16", 21/64", 11/32", 23/64", 3/8", 25/64", 13/32", 27/64", 7/16", 29/64", 15/32", 31/64", 1/2"

CODE: SI29COTP

25
PCE

26
PCE

STAINLESS Plus Jobber Drills

**5x
LIFE**

**FAST
spiral
FLUTE**

**TiAIN
COATING**
for ultimate
wear
resistance

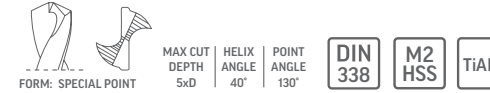

Ideal for: stainless steel, steel & aluminium

- 40° helix fast spiral flute for controlled chip evacuation
- Titanium aluminium nitride (TiAIN) coated for ultimate wear resistance
- 130° special point angle for quick penetration & reduced work hardening

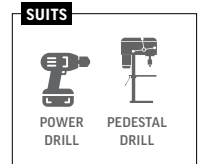
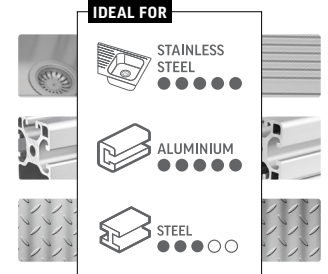

25 PCE Metric

Sizes: 1.0, 1.5, 2.0, 2.5, 3.0, 3.5, 4.0, 4.5, 5.0, 5.5, 6.0, 6.5, 7.0, 7.5, 8.0, 8.5, 9.0, 9.5, 10.0, 10.5, 11.0, 12.0, 12.5 & 13.0mm

CODE: SM25SPTP

26 PCE SITE READY Metric

Sizes: 2.0, 2.0, 2.5, 3.0, 3.0, 3.3, 3.5, 4.0, 4.0, 4.2, 4.5, 5.0, 5.0, 5.5, 6.0, 6.5, 6.8, 7.0, 7.5, 8.0, 8.5, 9.0, 10.0, 11.0, 12.0, 13.0mm

CODE: SM26SPTP

NEW

25
PCE

26
PCE

29
PCE

GOLD Series Jobber Drills

**30%
MORE
HOLES***

**TITANIUM
NITRIDE
COATING**
for faster
drilling &
longer life



FORM: SPLIT POINT

MAX CUT DEPTH 5xD
HELIX ANGLE 30°
POINT ANGLE 135°

DIN 338

M2 HSS

TiN

Ideal for: steel, wood, plastic & stainless steel

- 135° split point cuts faster & reduces wandering
- Titanium nitride coating reduces heat & increases lubricity for extended life



STRAIGHT SHANK

25 PCE Metric

Sizes: 1.0, 1.5, 2.0, 2.5, 3.0, 3.5, 4.0, 4.5, 5.0, 5.5, 6.0, 6.5, 7.0, 7.5, 8.0, 8.5, 9.0, 9.5, 10.0, 10.5, 11.0, 12.0, 12.5 & 13.0mm

CODE: SM25TP

26 PCE SITE READY Metric

Sizes: 2.0, 2.0, 2.5, 3.0, 3.0, 3.2, 3.5, 4.0, 4.0, 4.2, 4.5, 5.0, 5.0, 5.5, 6.0, 6.5, 6.8, 7.0, 7.5, 8.0, 8.5, 9.0, 10.0, 11.0, 12.0, 13.0mm

CODE: SM26TP

NEW

29 PCE Imperial

Sizes: 1/16", 5/64", 3/32", 7/64", 1/8", 9/64", 5/32", 11/64", 3/16", 13/64", 7/32", 15/64", 1/4", 17/64", 9/32", 19/64", 5/16", 21/64", 11/32", 23/64", 3/8", 25/64", 13/32", 27/64", 7/16", 29/64", 15/32", 31/64", 1/2"

CODE: SI29TP



IDEAL FOR

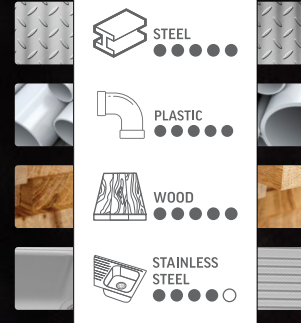

SUITS

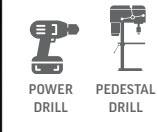

25
PCE

26
PCE

29
PCE

BLACK Series Jobber Drills

TEMPERED
BLACK
FINISH

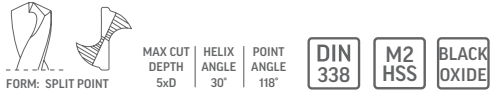

Ideal for: steel, hard ferrous metals, wood & plastic

- 118° split point reduces wandering
- Black oxide coating maximises lubricant hold, therefore assisting chip flow & heat dissipation
- Corrosion resistant finish
- Fully ground M2 HSS raw material for extended life

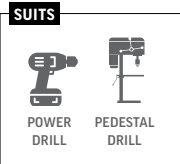
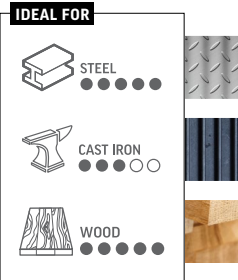

25 PCE Metric

Sizes: 1.0, 1.5, 2.0, 2.5, 3.0, 3.5, 4.0, 4.5, 5.0, 5.5, 6.0, 6.5, 7.0, 7.5, 8.0, 8.5, 9.0, 9.5, 10.0, 10.5, 11.0, 12.0, 12.5 & 13.0mm

CODE: SM25BTP

26 PCE SITE READY Metric

Sizes: 2.0, 2.0, 2.5, 3.0, 3.0, 3.2, 3.5, 4.0, 4.0, 4.2, 4.5, 5.0, 5.0, 5.5, 6.0, 6.5, 6.8, 7.0, 7.5, 8.0, 8.5, 9.0, 10.0, 11.0, 12.0, 13.0mm

CODE: SM26BTP

NEW

29 PCE Imperial

Sizes: 1/16", 5/64", 3/32", 7/64", 1/8", 9/64", 5/32", 11/64", 3/16", 13/64", 7/32", 15/64", 1/4", 17/64", 9/32", 19/64", 5/16", 21/64", 11/32", 23/64", 3/8", 25/64", 13/32", 27/64", 7/16", 29/64", 15/32", 31/64", 1/2"

CODE: SI29BTP

25
PCE

26
PCE

SILVER Series Jobber Drills



Ideal for: general purpose drilling in steel, wood & plastic

- 118° split point reduces wandering
- Fully Ground M2 HSS raw material for extended life

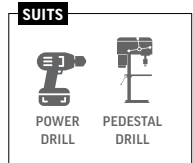
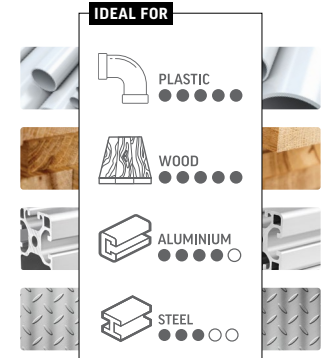

25 PCE Metric

Sizes: 1.0, 1.5, 2.0, 2.5, 3.0, 3.5, 4.0, 4.5, 5.0, 5.5, 6.0, 6.5, 7.0, 7.5, 8.0, 8.5, 9.0, 9.5, 10.0, 10.5, 11.0, 12.0, 12.5 & 13.0mm

CODE: SM25STP

26 PCE SITE READY Metric

Sizes: 2.0, 2.0, 2.5, 3.0, 3.0, 3.2, 3.5, 4.0, 4.0, 4.2, 4.5, 5.0, 5.0, 5.5, 6.0, 6.5, 6.8, 7.0, 7.5, 8.0, 8.5, 9.0, 10.0, 11.0, 12.0, 13.0mm

CODE: SM26STP

NEW

6
PCE

Reduced Shank Drills

HEAVY DUTY

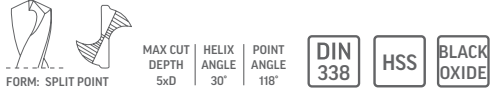

Ideal for: steel, wood, plastic & stainless steel

- 118° split point cuts faster & reduces wandering
- Black oxide coating maximises lubricant hold, therefore assisting chip flow & heat dissipation
- 3 flats on shank, prevents slippage in chuck
- Full length ground from a single piece of HSS eliminating breakage
- 12.7mm non-slip shank

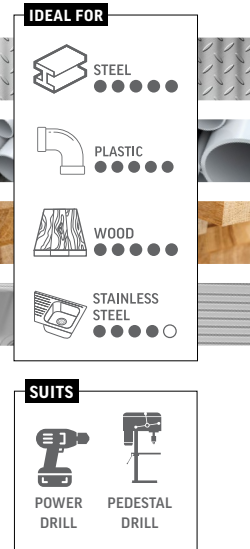

6 PCE Metric
Sizes: 14.0, 15.0, 16.0, 18.0, 19.0, 20.0

CODE: SM6RTP-B

3
PCE

THUNDER MAX

Step Drills 2 Flute - Spiral

2x LIFE

TEMPERED BLACK FINISH

MADE IN UK

AVAILABLE SEPTEMBER



Ideal for non-ferrous metals, sheet metals, plastic & stainless steel

- Drills & deburrs in one process
- Self-starting split point removes the need for a pilot hole
- Tempered black finish maximises lubricant hold, therefore assisting chip flow & heat dissipation
- Corrosion resistant finish

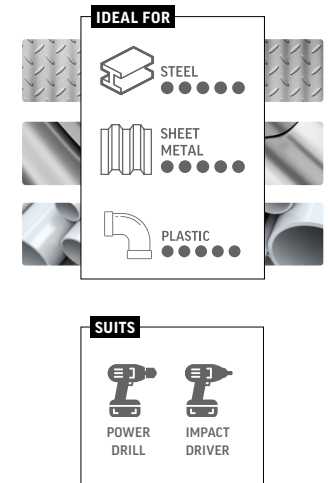

3 PCE Metric
4 - 12mm
4 - 20mm
6 - 30mm

CODE: SM3SDTP-B

7
PCE

IMPACT

Thin Metal Holesaw

HEAVY DUTY



Ideal for fast sheet metal cutting: electrical installation, switchboards, cable ducting & general sheet metal fabrication

- Stepped wall design to prevent over-drilling
- Thin wall 8/12 variable tooth configuration for fast, smooth & burr-free cutting
- Bi-metal HSS Holesaw for toughness & longer life
- TiN coated self-centering pilot drill reduces heat & increases lubricity for extended life
- Spring for instant plug ejection

1/4" QUICK CHANGE



7 PCE Metric

- 19.0mm
- 22.0mm
- 25.0mm
- 29.0mm
- 32.0mm
- 35.0mm

Spring Pilot Drill

Spare Hex Key Included

CODE: SM7HSFTP

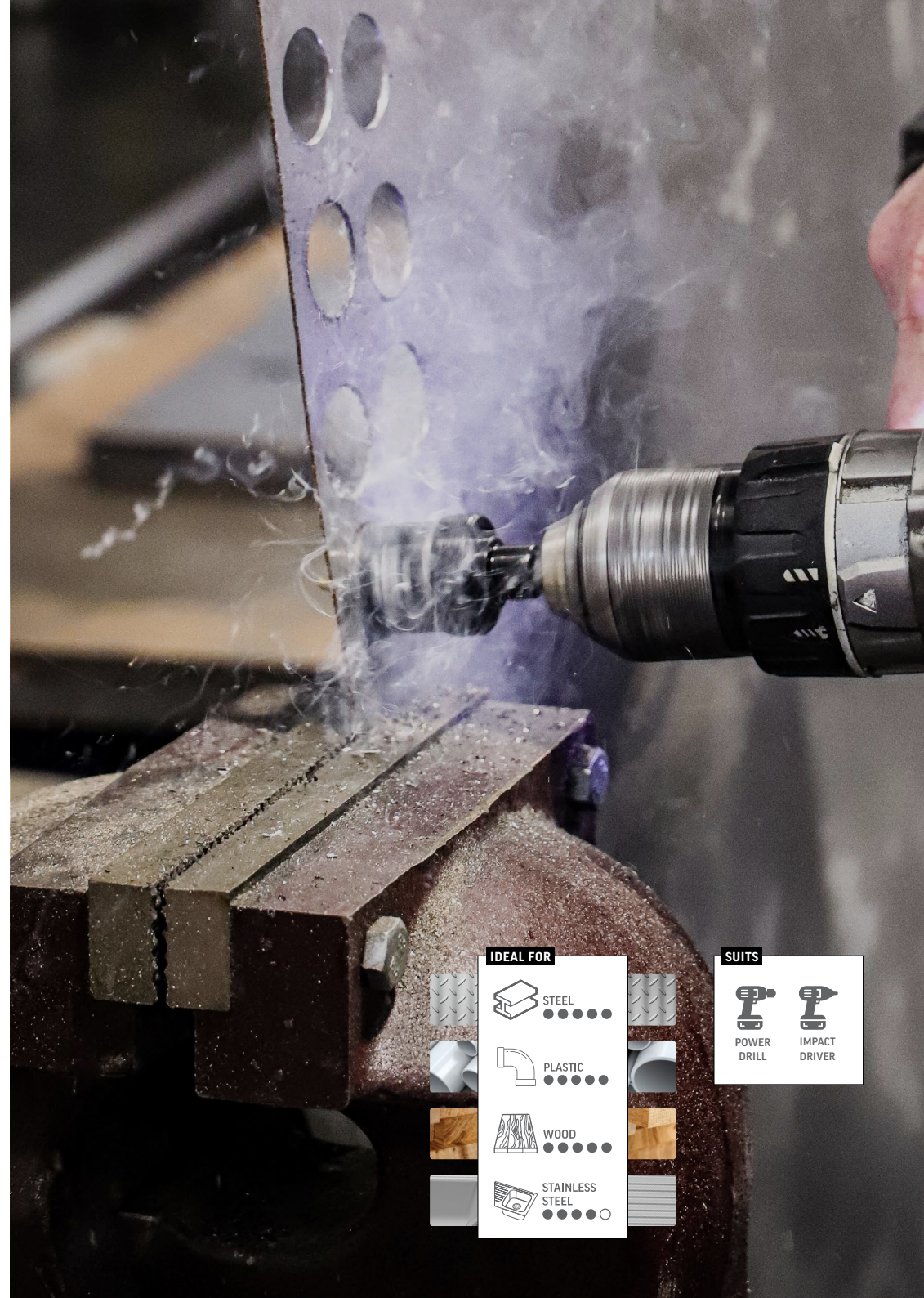

IDEAL FOR

- STEEL
- PLASTIC
- WOOD
- STAINLESS STEEL

SUITS

- POWER DRILL
- IMPACT DRIVER

28
PCE

Drill & Tap

METRIC & UNC

Carbon **XTRA**

GOLD Series

Ideal for: Steel, aluminium, copper & brass

- **Manufactured from premium European raw material**
- **With a unique composition** including high levels of Chromium, Vanadium & Nickel
- **Precision hardened to 60HRC** producing a tap that significantly outlasts & outperforms standard carbon taps

Ideal for: steel, wood, plastic & stainless steel

- **135° split point** cuts faster & reduces wandering
- **Titanium nitride coating** reduces heat & increases lubricity for extended life

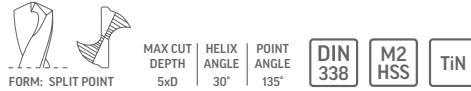

28 PCE Metric & UNC

Carbon Xtra Hand Taps Metric Intermediate

- M3 x 0.5
- M4 x 0.7
- M5 x 0.8
- M6 x 1.0
- M8 x 1.25
- M10 x 1.5
- M12 x 1.75

Carbon Xtra Hand Taps UNC Intermediate

- 6G x 32
- 8G x 32
- 10G x 24
- 1/4 x 20
- 5/16 x 18
- 3/8 x 16
- 1/2 x 13

GOLD Series Drills Metric Tapping

- 2.5mm
- 3.3mm
- 4.2mm
- 5.0mm
- 6.8mm
- 8.5mm
- 10.2mm

GOLD Series Drills UNC Tapping

- 2.8mm
- 3.4mm
- 3.8mm
- 5.1mm
- 6.6mm
- 8.0mm
- 10.8mm

CODE: SMUHT28TP-B

23
PCE

Drill, Tap & Die

METRIC

Carbon **XTRA**

GOLD Series

Ideal for: Steel, aluminium, copper & brass

- **Manufactured from premium European raw material**
- **With a unique composition** including high levels of Chromium, Vanadium & Nickel
- **Precision hardened to 60HRC** producing a tap that significantly outlasts & outperforms standard carbon taps

Ideal for: steel, wood, plastic & stainless steel

- **135° split point** cuts faster & reduces wandering
- **Titanium nitride coating** reduces heat & increases lubricity for extended life

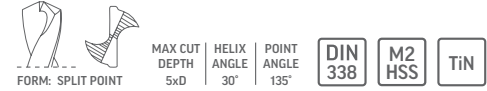
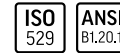

23 PCE Metric

GOLD Series Drills Metric Tapping

- 2.5mm
- 3.3mm
- 4.2mm
- 5.0mm
- 6.8mm
- 8.5mm
- 10.2mm

Carbon Xtra Taps Metric Intermediate

- M3 x 0.5
- M4 x 0.7
- M5 x 0.8
- M6 x 1.0
- M8 x 1.25
- M10 x 1.5
- M12 x 1.75

Carbon Xtra Button Dies Metric Coarse

- M3 x 0.5
- M4 x 0.7
- M5 x 0.8
- M6 x 1.0
- M8 x 1.25
- M10 x 1.5
- M12 x 1.75

Tap Handle TW-0 M3 - M12

Button Die Wrench 1" BDW-1

CODE: SM23DTDP-B

8
PCE

REO HEAD

SDS Drills 4 Head Cut



Ideal for hard masonry drilling: REO concrete, masonry & concrete

- REO Head delivers up to 6x longer life in concrete with rebar compared to professional 4-cutter SDS drills
- Solid Carbide Head for fast & accurate drilling performance
- Superior head design prevents jamming when drilling through rebar
- 4 flute design for high volume dust removal
- German manufactured & PGM[®] Certified for guaranteed hole accuracy



- 8 PCE Metric
- 5.0 x 165mm
 - 5.5 x 165mm
 - 6.0 x 165mm
 - 6.5 x 165mm
 - 8.0 x 165mm
 - 10.0 x 165mm
 - 12.0 x 165mm
 - 14.0 x 165mm

CODE: SM8SPZTP



Alpha Tools

Alpha ThunderMax Cleanable Nutsetters are game changers with removable sockets for easy to remove swarf



Alpha Tools

Gold Series Jobber Drills drill 6x faster!!!



Alpha Tools

Unleash the Fury of cool grinding and fast removal with Alpha's new Fury Flap disc!



Alpha Tools

Onsite+ Step Tip Drill bit drills 3 holes in 21.8 seconds. Standard jobber drills complete 2.5 in 106 seconds...



Alpha Tools

WIN! Fill out our 3 minute survey for your chance to win a portable outdoor oven valued at \$699!

LEAD THE PACK FOLLOW US

@alphatoolsaus



TUFFBOX **PRO**



POWERED BY  Sheffield GROUP

alphatools.com.au

