



INSTALLATION MANUAL

SELFLOK WEATHERBOARDS



EXTERNAL CLADDING 2022

A better choice, naturally

Contents

- Introduction.....3
- Accreditations4
- 1 GENERAL INSTALLATION INFORMATION5**
 - 1.1 Product Information5
 - 1.2 Fire Rated Wall Systems6
 - 1.3 NCC Compliance.....7
 - 1.4 General Requirements.....8-10
 - 1.5 Painting: Pre-Primed.....11
 - 1.6 Staining: Natural Range.....12
 - 1.7 Maintenance.....13
 - 1.8 Steel Frames.....14-15
 - 1.9 Cavity System.....16-17
 - 1.10 Physical Properties.....18
- 2 SELFLOK WEATHERBOARDS19**
 - 2.1 Selflok Weatherboards.....19
 - 2.2 Accessories20-21
 - 2.3 Fasteners22-23
 - 2.4 Installation24-26
- MANUFACTURERS WARRANTY27**

ALL OTHER WEATHERTEX PRODUCTS

To view and read all other Weathertex product installation manuals visit weathertex.com.au

Introduction



MADE IN AUSTRALIA

Family owned and manufactured in the Hunter region, NSW since 1939.



SAFE

Low VOC. Meets Australian Building Standards. 100% natural product. CodeMark Australia certified - Selflok. No added silica, glues, resins or formaldehydes.



TRUSTED

WeatherTex voted #1 MOST TRUSTED brand in the building industry by Architecture & Design latest survey. Won SUPPLIER OF THE YEAR in the Australian Construction Awards.



STYLISH CHOICES

A wide selection of profiles available in various styles, textures and sizes. Easy to incorporate the natural with primed profiles together to offer multiple design options. Curved walls can be achieved down to a minimum of 2.5m radius for Selflok.



SUSTAINABLE

Better than zero carbon footprint with Third Party Credentials - GreenTag certification, PhD, PEFC. Low embodied energy.



VALUE FOR MONEY

No special tools required for cutting. Lightweight product - reduces labour costs.



DURABLE

Termite Resistant. Warranty tried and tested not to rot, split or crack for up to 25 years. Natural range is the only timber product in the market to provide a 10 year warranty. 1000 kg/m³ product density with a minimum 32MPa rating. Watertight - mechanical flashing and joining accessories mean that sealant control joints are seldom required.



QUICK & EASY INSTALLATION

9.5mm thickness and matching accessories across all products making it easier to mix multiple profiles within a project. Easier to paint than other materials on the market due to its smoother surface.



Accreditations

The CodeMark Certification Scheme (the Scheme) is a voluntary third-party building product certification scheme that authorises the use of new and innovative products in specified circumstances in order to facilitate compliance with Volumes One and Two of the NCC, also known as the Building Code of Australia or BCA.

CodeMark provides confidence and certainty to regulatory authorities and the market through the issue of a Certificate of Conformity, which is one of several options available for meeting the 'evidence of suitability' requirements of the BCA.

Our 'Green' Accreditations

A rigorous life-cycle evaluation has been conducted by Global GreenTag International to determine the 'environmental performance' of our products. We are proud to announce we have been the FIRST GLOBAL manufactured product to receive their highest Platinum certification for our Natural Range and a Gold certification for all our flat primed profiles.

2018 Supplier of the Year at the Australian Construction Awards.

The industry relies on a number of stakeholders to keep projects moving. Supplier of the year is a company that provided quality, on time, every time.

A&D's Most Trusted Brand Award x 2 consecutive wins (2016 & 2018). Architecture and Designs 'Top Trusted Brand' biennial survey reveals Australia's top brands within the architecture, building, construction and design industries

Weathertex sources timber from sustainably managed forests and controlled sources audited under the Australian Forestry Standard (AFS) and Certified by PEFC: the world's largest forest certification scheme.

Whether you are seeking timber cladding for a renovation, extension, new home, or commercial application, Weathertex weatherboards and architectural panels offer an endless variety of timber cladding solutions and styles.

A better choice, naturally.



NATURAL RANGE
IS PLATINUM GREENTAG CERTIFIED.

PRIMED RANGE
IS GOLD GREENTAG CERTIFIED.

THE FIRST MANUFACTURED PRODUCT GLOBALLY TO ACHIEVE PLATINUM GREENTAG™ CERTIFICATION



1.1 Product Information

1.1.1 DIMENSIONS AND PACKAGING

SELFLOK WEATHERBOARDS	LENGTH (mm)	WIDTH (mm)	UNITS PER PACK	CONTENTS m ²
Millwood	3660	298	96	104.7
Colonial	3660	298	96	104.7
Ecogroove 75	3660	298	96	104.7
Ecogroove 150	3660	298	96	104.7
Ecogroove 300	3660	298	96	104.7
Texwood	3660	298	96	104.7
Vgroove 150	3660	298	96	104.7

1.1.2 WEATHERBOARD WALL COVERAGE TABLE

	ALL SELFLOK PROFILES
Weatherboard Width	298
Weatherboard Lap	19
NUMBER OF ROWS (x)	WALL HEIGHT COVERAGE (mm)
Approximation	= 279x + 19
1	298
2	577
3	856
4	1135
5	1414
6	1693
7	1972
8	2251
9	2530
10	2809
11	3088
12	3367

NOTES:

1. Manufacturing and installation tolerances apply
2. Weathertex Selflok have set weatherboard laps. The top row of Weatherboards may require cutting to fit to the eaves
3. At the wall/eave intersection a timber cover strip or quad may be fixed for a tidy finish
4. Checking row height alignment around corners is important to avoid creep due to small differences in board tolerances and tightness of installation

1.2 Fire Rated Wall Systems

Weathertex has been assessed by an Accredited Testing Laboratory, that the attachment of Weathertex 9.5mm cladding systems detailed in Table 1.2.1 over plasterboard timber and steel plasterboard lined walls that has been either tested or assessed to achieve an FRL up to and including 90/90/90, would not detrimentally affect the FRL of the underlying wall system if testing in accordance with AS 1530.4:2014.

1.2.1 TABLE - ALLOWABLE FIXING OPTIONS OVER PLASTERBOARD FRL SYSTEMS

CLADDING SYSTEM	UNDERLYING PLASTERBOARD SYSTEM	
	TIMBER FRAMING	STEEL FRAMING
Direct fix	✓	✗
9.5mm Weathertex cavity system	✓	✗
20mm Pine batten cavity system	✓	✓
35mm Pine batten cavity system	✓	✓
45mm Pine batten cavity system	✓	✓
Steel top hat (min 0.55 BMT G550)	✓	✓

These fire rated wall systems are detailed by the relevant system manufacturer such as USG Boral. Advice of the system manufacturer should be sought on the appropriate system for your project.

All walls must be designed for the applied loads. For load-bearing walls and walls subject to wind pressures, walls shall be designed to the appropriate Australian Standards or construction manuals. Designers should consider Axial Capacity Reduction (ACR) from charring or loss of steel strength due to heat. Guidance on structural design can be sought from the relevant FRL system manufacturer.

Standard installation requirements in this installation guide apply to the installation of the Weathertex external cladding component. Fastener lengths must be increased by the thickness of all packing materials used between the structural frame and Weathertex.

USG BORAL Systems+ OUTERWALL.

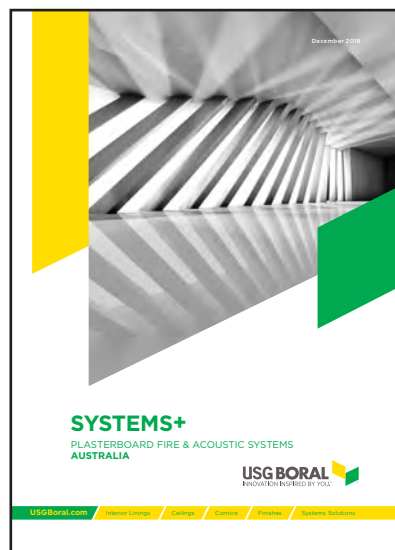

EXAMPLE FRL SYSTEM DESCRIPTION (60/60/60 Outside only)

EXTERNAL WALL SIDE

- Weathertex 9.5mm Cladding
- Vapour permeable membrane
- 1 layer 16mm FIRE WETSTOP

CAVITY INFILL:

- R2.5 GW Wall Batts

INTERNAL WALL SIDE

- 1 layer of 10mm STANDARD Plasterboard

1.3 NCC Compliance

Evidence of Suitability supporting the use of Weathertex to meet relevant Performance Requirements and Deemed-to-Satisfy requirements are available. Please contact the Weathertex technical team (ph:1800 040 080) for relevant compliance documentation or visit our website - weathertex.com.au.



Image: Selflok Ecogroove 150 Natural

1.4 General Requirements

The following installation instructions and guides are in addition to local and state regulations and the requirements of the National Construction Code (NCC). Weathertex provides construction detail drawings which should be used in conjunction with the instructions in this installation manual.

NOTE: All diagrams in this installation manual are for demonstration purposes only. Diagrams may omit some components for clarity.

Deviation from standard applications and requirements detailed in this Installation Manual or supplementary Weathertex Construction Details may void the manufacturer's product warranty. The product specific installation instructions in this manual are applicable to steel and timber frames for both direct fix and cavity systems. Preparation steps must be followed for direct fix to timber frame, ventilated cavity construction and steel frame construction.

1.4.1 STORAGE AND HANDLING

Weathertex products should be stored flat, under cover and on timber bearers spaced at maximum 600mm centres. When storing Weathertex outside, keep the stack clear of the ground and cover with waterproof materials to prevent water staining.

NOTE: Weathertex factory stretch wrap is not designed to keep stored product weatherproof and should not be relied upon for primary weather protection.

Anodised aluminium products should be stored in a dry and flat position away from any potentially corrosive or incompatible materials. Timber or soft bearers at a distance no more than one metre apart should be used to support the product. Continuous exposure to moisture will promote corrosion. Metal edges and cut corners of the product can be sharp and may cause personal injury if not handled safely. Wear eye protection, gloves and protect skin when possible and when cutting avoid air borne metal fragments.

1.4.2 CUTTING AND WORKING WITH WEATHERTEX

Weathertex products are easy to cut and shape with a normal hand or power saw. Weathertex may be stacked two or three high for multiple cutting. Where required, edges may be trimmed with a smoothing plane or sandpaper. Holes are easily drilled with high speed drills or clean cutter bits. For best results break cut edges with a 2mm chamfer. Clean all dust from flashing as work progressed, as it may mix with water and create a brown runoff. Cut edges, holes and countersinks must be re-primed with a high quality tannin blocking exterior timber primer (water or solvent based). Excluding our Natural range.

The normal health and safety precautions should be taken when working with wood panel products. Machining equipment should be fitted with dust collection devices and used in well ventilated areas. Follow good hygienic and housekeeping practices. Wood dust can be vacuumed, shovelled or swept to avoid accumulation. If dust levels exceed Safe Work Australia Standards the wearing of a dust mask (AS 1715 and AS 1716) and safety glasses (AS 1337) is recommended. Storage and work areas should be adequately ventilated.

A Safety Data Sheet is available for download on the Weathertex website: weathertex.com.au

1.4.3 SITE, FOUNDATION AND FRAMING

Foundation design must comply with AS 2870 "Residential Slabs and Footings - Construction" and the National Construction Code (NCC). Timber or steel frames shall comply with the NCC. Where applicable, timber frames shall be constructed in accordance with Australian Standard 1684 - Residential Timber - Framed Construction. Steel frames must be erected in accordance with the manufacturer's requirements. Frames shall be straight and true with studs at a maximum of 600mm centres. Timber shall be seasoned, as unseasoned timber is prone to shrinkage and can cause sheets and frames to move.

1.4.4 GROUND CLEARANCES

Lower framing timbers must be isolated from ground moisture by suitable damp-proof courses (DPC) or termite shielding. Similarly, weatherboards must not be placed in direct contact with masonry, brickwork or concrete. Where necessary, use strips of Alcor to isolate the materials. The bottom edge of weatherboards must be kept clear of paved surfaces by a minimum of 100mm and a minimum of 225mm for unprotected ground (i.e. grass, gardens etc). Weatherboards must extend a minimum of 50mm below the bearer or lowest horizontal part of the of suspended floor framing for a suspended floor system. The grade of adjacent finished ground must slope away from the building to avoid the possibility of water accumulation. Typically this is a minimum slope of 50mm over the first metre, however please refer to the minimum slope required from local building codes and regulations. Weathertex must not be installed in wet areas and where it comes in contact with standing water.

NOTE: To comply with termite protection provisions a greater clearance may be required. See 'Weathertex and Termite protection' in section 1.4.10.

1.4.5 LENGTH OF WALL REQUIREMENTS

For continuous walls less than 5.5m, all product specific joining methods may be used. On continuous walls greater than 5.5m, traditional & aluminium joining methods must only be used. For continuous walls greater than 11m long, engineers/designers must assess additional requirements for frame and cladding control joints, alternatively please call Weathertex (Ph 1800 040 080) for additional advice.

NOTES:

- For specific joining methods applicable to each product, refer to specific product section.

1.4.6 MOISTURE MANAGEMENT AND FLASHING

Weathertex weatherboards are intended for use as internal and external cladding in standard stud wall systems. It is the responsibility of the Designer or Specifier to identify moisture related risks associated with any particular building design. Wall construction and design must effectively manage moisture, considering both the interior and exterior environments of the building, particularly in buildings that have a high risk of wind driven rain or are artificially heated or cooled. Adequate design of ventilation, flashings and moisture management systems must ensure that the wall cavity and the back of the Weathertex board will remain dry at all times.

In addition, all wall openings, penetrations, junctions, vertical and horizontal joins, connections, window heads, sills and jambs or other components, must incorporate appropriate NCC complying flashing for waterproofing to prevent moisture exposure on the back of the Weathertex. Flashing materials and methods must comply with the requirements of Weathertex, and where flashing materials are not specified by Weathertex refer to the Australian Standards &/or NCC. Failure to appropriately flash all penetrations will void the Weathertex Manufacturer's Warranty.

On walls projecting from the roof line in upper storey construction, keep the bottom edge of Weathertex cladding 70mm clear of the lower storey roof claddings. Weatherproof with an approved flashing. For product specific details please refer to the relevant construction details on weathertex.com.au.

1.4.7 WALL SARKING REQUIREMENTS

Vapour permeable membrane must be used under all Weathertex external wall systems. The vapour permeable membrane allows for the controlled escape of vapour from within the building whilst restricting the ingress of liquid moisture.

Weathertex recommends the use of Vapour permeable membrane in conjunction with the Weathertex Cavity Installation System to provide the best protection against condensation problems such as mould, timber rot, corrosion and loss of thermal resistance. Resources such as the ABCB Condensation Handbook and NATSPEC offer general information on condensation principles.

NOTE: Soft compressible products such as insulation installed directly between the front of the wall studs and Weathertex cladding is not compatible with Weathertex products and will void the product warranty.

SARKING REQUIREMENTS FOR CLIMATE ZONES 2 - 8

Material Standard	AS/NZS 4200.1
Installation Standard	AS 4200.2
MANDATORY PROPERTIES	
Vapour Resistance	Class 4
Water Barrier	Passing AS/NZS 4201.4
Flammability index	NOT MORE THAN 5

*sarking products are unsuitable if classed as a "Non-water Barrier" as per AS/NZS 4200.1 clause 5.3.5. and will void the Weathertex product warranty.

1.4 General Requirements

1.4.8 RECOMMENDED VAPOUR PERMEABLE MEMBRANE PRODUCTS

The permeability and vapour resistance of materials should be considered in the context of their application. The designers/architects/engineer should consider strategies to mitigate condensation risks in the design with relevance to local climate conditions. Suitable membrane products for moisture control in hot wet and humid conditions (Climate Zone 1) should be discussed with the membrane manufacturer.

Recommended accessories required for AS 4200.2 installation are Waterproofing tapes such as Bradford Enviroseal™ HighTack Adhesive Tape & Pro clima TESCON EXTORA® or equivalent, and Sill tapes such as Enviroseal™ Proctorwrap SLS Flexi Tape & Pro clima TESCON EXTOSEAL® or equivalent.

		Product: Enviroseal Proctor Residential (RW) OR Commercial (CW)	
		Product: Ametalin VapourTech® Wall Residential & Commercial	
		Product: Thermakraft Watergate Plus	

1.4.9 CONSTRUCTION DETAILS

Please refer to the Weathertex website for the complete suite of construction details for all products and applications weathertex.com.au

1.4.10 WEATHERTEX AND TERMITE PROTECTION

The NCC specified the requirements for termite barriers. All of these requirements must be satisfied. Where the exposed slab edge is used as a part of the termite barrier system, a minimum of 75mm of the exposed slab edge must be visible to permit ready detection of termite entry.

Weathertex currently provides a warranty which protects against a variety of conditions including (but not exclusive of) the product supplied being fit for purpose, and will not rot, split or crack. In addition to this, Weathertex is warranted against termite attack, provided the following conditions are adhered to.

A termite mitigation plan complying with all local, state and federal requirements and best-practice guidelines must be in place and maintained from the time that the Weathertex is delivered to site and for the life of the product. Provided that the plan and its maintenance can be demonstrated, the normal Weathertex warranty at the time of purchase will apply to the Weathertex.



Samples removed from Termite Test after 2.5 years exposure

1.5 Painting: Pre-Primed

1.5.1 PRE-PRIMED PRODUCTS

PRIMER:

WeatherTex factory primer is designed to be painted within 60 days of installation. Failure to do so can result in poor topcoat adhesion and will void warranty. Lightly sand any nibs or blemishes which have occurred during fixing. Cut edges, holes and countersinks must be re-primed with high quality tannin blocking exterior timber primer (water or solvent based). A spray primer is the most efficient method. It is also good practice to prime any timber mouldings, including corner stops and trims.

Trimtec aluminium accessories are protected by an anodised coating and can be left unpainted if desired. Due to their smooth surface, aluminium accessories should be etch primed if a topcoat is to be applied.

SURFACE PREPARATION - CLEANING & WASHING:

Clean surface of primed WeatherTex products using a soft broom or soft lint-free cloth and wash down with sugar soap to remove salt, dirt, dust and grease or airborne contaminants. Do not vigorously scrub the surface nor use an abrasive or strong cleaning agent as you may burnish the paint surface and mark the primer finish. Wash down with fresh water and dry the surface with one final wipe using a soft dry lint-free cloth in the direction of the paint flow. Do not use high pressure washers as this can cause coating damage and water ingress into the wall cavity.

Not allowing the WeatherTex to dry before painting is a common cause of paint failure. Failure to clean the surface may result in poor adhesion with topcoat and may void warranty.

1.5.2 PAINTING PRE-PRIMED PRODUCTS

PAINTING:

The primed surface of WeatherTex products are suitable for the application of exterior grade water or solvent based topcoat paint systems. It is recommended to apply selected coating to a test area to confirm suitability. If compatibility of the selected topcoat is an issue, the surface may be primed with a suitable tannin blocking exterior primer per the coating manufacturer's recommendation before painting. Contact the paint manufacturer for advice or information.

When top coating, apply a minimum of two coats of paint in accordance with the paint manufacturer instructions for mixing, film build, coverage and drying between coats. Temperature and wet weather will affect curing of coatings and consideration of site conditions at the time of painting is essential to ensure proper curing and adhesion. Paint additives may adversely affect the coating adhesion and durability and should only be used with the endorsement of the coating manufacturer.

PAINT COLOUR:

WeatherTex hardboard products have 50 years proven durability in the harshest of climate zones. While there is no restriction on the vast array of colours to paint your home, it is important to understand the effect paint colours can have on the performance of construction products.

As WeatherTex is a timber product, its dimensions will expand and contract with changes in moisture content. Dark paint colours can allow surfaces in warmer climates to become very hot in direct sunlight leading to loss of moisture and subsequent shrinkage of the weatherboard. Selection of light paint colours with high Light Reflectance Values (LRV) will lead to better thermal efficiency of the building, improve the maintenance cycles of paint coatings and sealants while minimising the thermal expansion and contraction of all construction components. With darker paint colours we recommend prepainting the ends of the weatherboard prior to installation of joining/corner accessories.



1.6 Staining: Natural Range

1.6.1 NATURAL PRODUCTS

The Weathertex Natural Range are uncoated hardwood timber products that will fade to a rustic grey with UV exposure just like raw timber. Manufactured with a mixture of native Australian eucalypt species, the original colour and greying process can vary due to the seasonal variation of harvesting areas.

Weathertex Natural may be left raw to grey off, be stained with a quality decking stain to maintain the rich appearance of new timber / stained with a controlled erosion stain for timber to mimic greying off and maintained as per below.

NOTES:

1. Painting Natural range with a standard top coat (paint) finish or a clear coat will void the manufacturer's warranty. If a top coat finish is to be applied, it must be onto Weathertex's pre-primed products.
2. Varnishes, oils & clear coats are not suitable for external applications of Weathertex products. They do not provide adequate UV protection, their inflexibility can result in cracking/crazing and when externally exposed can cause irregular and blotchy surface aesthetics. It is the customer's responsibility to confirm coating suitability from the coating manufacturer.

SURFACE PREPARATION - CLEANING & WASHING:

After installation, prepare the surface by removing dust and contaminants with an Oxalic Acid based timber cleaner solution. A soft broom or cloth may be used to gently scrub all surfaces. Wash down with fresh water and allow to completely dry. Not allowing the board to dry before coating is a common cause of coating failure. Failure to properly prepare the surface may result in poor adhesion and may void the coating manufacturer's warranty. Never use high pressure washers as this can cause coating or even board damage and water ingress into the wall cavity.

1.6.2 STAINING NATURAL PRODUCTS

STAINING:

Apply 2-3 coats minimum of a recommended water based deck stain in accordance with the staining manufacturer's application instructions. It is best to brush apply staining to ensure proper penetration into the wood grain surface. Cutting in should be performed after the first coat is applied to avoid a dry-line border in the finish. Weathertex Natural may also be left to lighten before staining for different colour results. Staining providers offer a wide range of colours that may be used and a test sample should always be performed to confirm colour expectations and performance before staining.

COATING WITH A CONTROLLED EROSION STAIN PRODUCT:

Apply a controlled erosion stain in a colour that is in accordance with the staining manufacturer's instructions. Weathertex Natural may also be left to lighten before staining for different colour results. Staining providers offer a wide range of colours that may be used and a test sample should always be performed to confirm colour expectations and performance before staining.

WEATHERTEX LEFT NATURAL (UNCOATED):

Left to weather naturally by the sun, the uncoated timber will lighten and "grey off" over time similar to raw hardwood. The degree and speed of colour change will depend on the intensity of UV exposure. The design of the installation must allow for consistency of sun exposure as shade lines caused by other features will result in colour variation and inconsistent weathering patterns. When allowed to weather naturally some small black spots on the surface may become more visible. This is carbon which is inherent within raw timber and the manufacturing process. These small black spots are not mould and will not affect the performance or longevity of the product.

NOTE: Natural Products are composed of unsealed natural hardwood timber which may occasionally exhibit tannin bleeding. Consideration must be taken if installing unsealed Weathertex products above porous or light coloured features.



1.7 Maintenance

1.7.1 PRE-PRIMED PRODUCTS

The extent and nature of maintenance will depend on the geographical location and exposure of the installation. Regularly wash the painted surface with mild soapy water to remove dirt and grime to improve the performance of the coating. Never use high pressure washers as this can cause coating damage and water ingress into the wall cavity.

Thoroughly inspect topcoat paint work at the end of year 1 and repair areas of damage/coating breakdown according to the original paint specification or approved equivalent. Repeat inspection process at year 5 and based on the results of this condition survey make a decision on future maintenance actions, which may include touch up/repair of areas or a full re-coat.

Additional basic maintenance tasks include but are not limited to; controlling vegetation and garden beds close to the installation, keeping gutters and pipes clear, addressing potential moisture damage due to overflows and replacement of penetrations, flashings and sealants used in installation as required.

Generally, exterior surface coatings deteriorate by chalking rather than flaking. When repainting becomes necessary and the surface is unbroken, remove loose chalk by lightly sanding and follow the preparation steps above. Reapply new coatings in accordance with the paint manufacturer's instructions.

1.7.2 NATURAL PRODUCTS

The extent and nature of maintenance will depend on the geographical location and exposure of the installation. Weathertex may be periodically cleaned with mild soapy water or a suitable timber cleaner. Do not use high pressure washers as this can cause coating damage and water ingress into the wall cavity. Additional basic maintenance tasks include but are not limited to controlling vegetation and garden beds close to the installation, keeping gutters and pipes clear, addressing potential moisture damage due to overflows and replacement of penetrations, flashings and sealants used in installation as required.

Thoroughly inspect any coatings at the end of year 1 and repair areas of damage/coating breakdown. Repeat inspection process at year 3 and based on the results of this condition survey make a decision on future maintenance actions, which may include touch up/repair of areas or a full single coat.

Generally, semi-transparent decking stains and controlled erosion stains are softer and less UV resistant than regular exterior paint resulting in a 3 - 5 year recoating cycle. When re-coating becomes necessary follow the preparation and coating steps above. A darker / more opaque stain colour may be required in time to maintain the desired colour of the boards.



0 MONTHS: Recently built, this shows the beginning colour of Weathertex Natural boards.



4 MONTHS: The board shows signs of lightening.



36 MONTHS: The boards are now very light, and are about to begin to be restored.

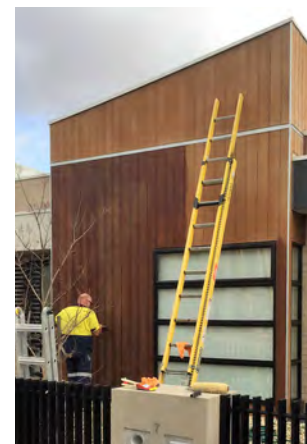

STAINING: Stain in the same direction that the boards run eg. Vertical for vertical cladding.

Failure to follow any of the above preparation instructions may void warranty of the product.

NOTE: Rate of fading may vary from above photos depending on environmental factors.

1.8 Steel Frames

The following information applies to Weathertex installed on 0.55 BMT minimum steel frames. Installing Weathertex onto a steel frame is generally similar to installing Weathertex on a timber frame. There is however some differences of which the installer must be aware and the following section outlines the technical information unique to steel frame installation.

1.8.1 FASTENERS

Appropriate fasteners must be used when installing onto steel frames. See the Fasteners Section and in relevant product section to select the correct fastener. Do not tap home under-driven gun nails as this can break the holding power of the fastener. Incorrectly shot nails should be removed and refastened at least 15mm away from the original fastener position.

1.8.2 INSTALLATION

Since 2007 there has been a Thermal Break provision within the Energy Efficiency requirements of the NCC. The provision is included to prevent thermal bridging across the wall cavity. Thermal bridging is a leakage of heat through a conductive path such as metal framing. Thermal bridging causes a reduction in the overall R-value of the wall system, significantly reduces the efficiency of the building's heating and cooling systems and can lead to condensation problems in the wall cavity.

In accordance with the NCC a rigid thermal break with R-value no less than 0.2 must be installed between the Weathertex external cladding and the metal framing members to separate both elements.

When installing Weathertex on a Steel Frame, thermal break battens create a cavity system. Refer to cavity fix construction details for more guidance. Butt-join the stud battens leaving a 5mm gap. Weathertex recommends the following two options as suitable thermal breaks.

1.8.3 RECOMMENDED THERMAL BREAKS

Softwood timber battens are easily installed to provide a suitable thermal break between Weathertex and a steel frame. The softwood timber battens shall be 20mm deep and wide enough to cover the face of the frame. For example if 70x35mm steel frame is chosen, the battens shall be 20x35mm at suitable length.

A suitable membrane must be installed between the steel frame and battens; see section on Wall Sarking Requirements. The membrane must be held in place temporarily, using suitable fasteners or the timber battens, before the battens and the Weathertex are installed.

Final fixings will hold battens firmly in place but they must be temporarily fixed to the frame at 600mm centres before the cladding can be installed.

Extruded polystyrene strips are an alternative to softwood timber battens for a thermal break solution. The extruded polystyrene strips shall be 12mm deep and wide enough to cover the face of the frame. For example if a 70x35mm steel frame is chosen, the battens shall be 12x35mm at suitable length.

Nails or screws cannot be used to secure expanded polystyrene strips to the frame. Instead, double-sided adhesive tape or construction adhesive is suitable to hold the strips in place on the frame. Final fixings will hold extruded polystyrene strips firmly in place.

1.8.4 CAVITY CLOSER

To protect against vermin and other material entering the cavity, the base of the cavity must be sealed using the Weathertex Large or Small Cavity Closer. A cavity closer must be installed at the base of the wall and above window heads and inter-storey flashings. The bottom of each batten is inserted into the cavity closer.

- Use 20mm Large Cavity Closer when using 20mm softwood timber thermal break battens (Applicable for all products).
- Use 10mm Small Cavity Closer when using polystyrene thermal break strips (Applicable for all products).

Fix the cavity closer to the base plate at 300mm centres. Butt-join cavity closers with max 2mm gap as required and ensure the closers are fixed in a straight, level line. It is important that the openings in the cavity closer are kept clear and unobstructed to allow free drainage and ventilation of the cavity.

1.8.5 INSTALLATION

Once the wall has been battened out as per cavity construction details, Weathertex's product specific standard fixing instructions shall be followed to install the cladding on to the frame.

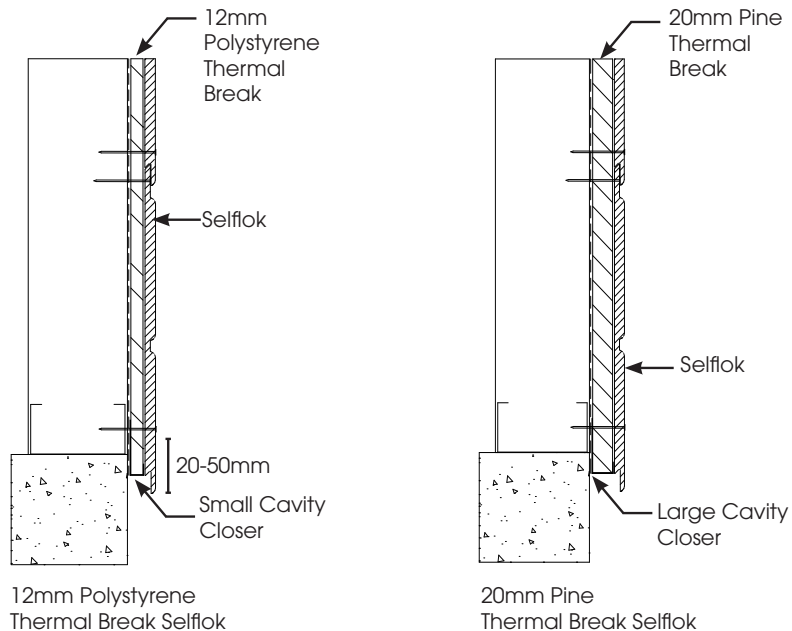
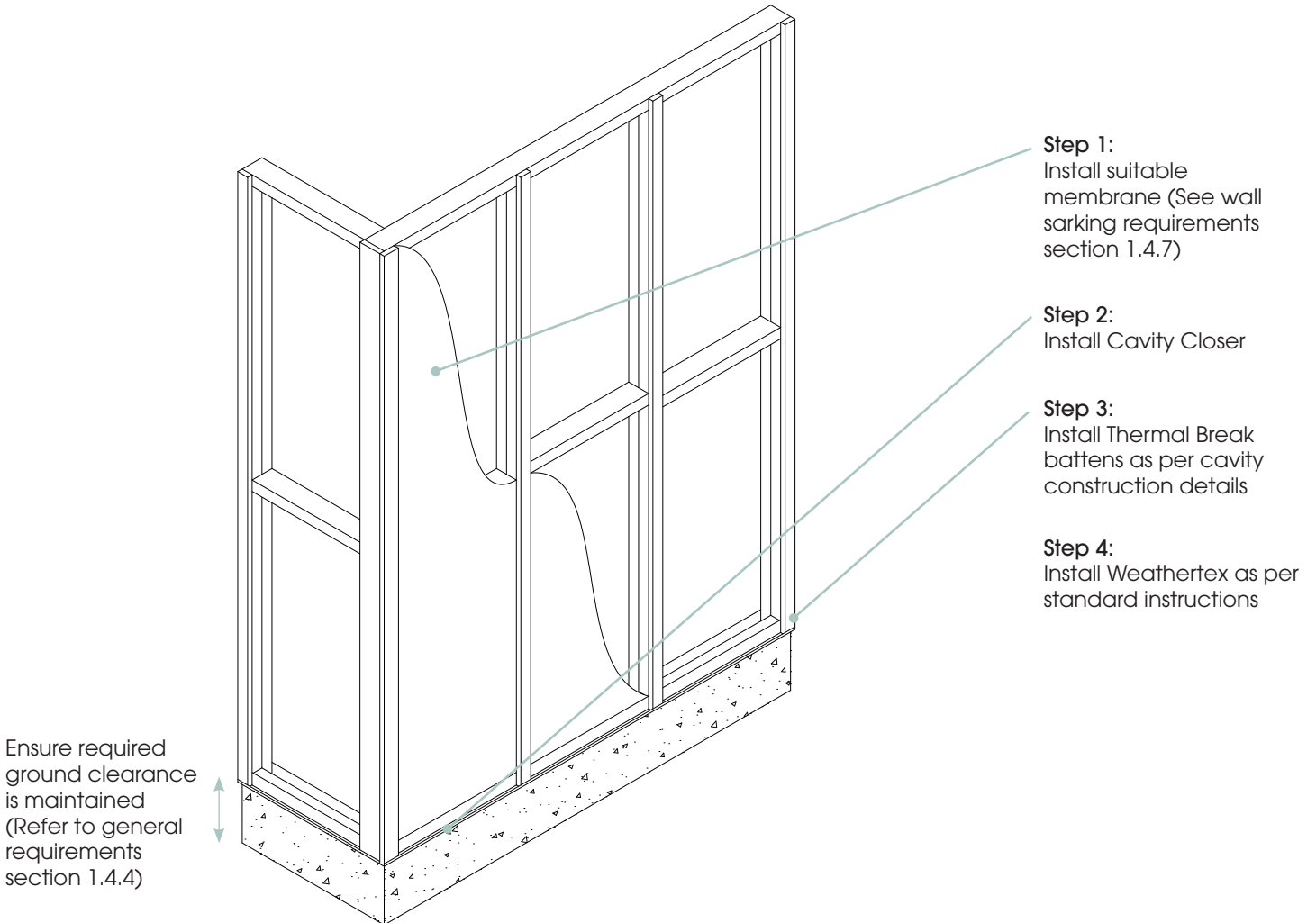

1.9 Cavity System

To provide the best protection for your wall against moisture and mould related problems Weathertex highly recommends the use of a cavity fixing system. Fixing over the Weathertex cavity system provides the best defence for your internal lining, frame, insulation and cladding against sick home syndrome. A cavity system creates a space within the wall that allows airflow to remove any moisture that accumulates in this space either from wind driven rain or condensation.

1.9.1 PREPARATION

Minimum requirements for fasteners must be followed when installing the Weathertex Cavity System. See the Fasteners Section when selecting appropriate fasteners.

A suitable membrane must be installed between the timber frame and battens; see section on Wall Sarking Requirements. The membrane can be secured by the timber battens as they are installed along a wall.

Care should be taken when installing bulk insulation to ensure the stud cavity is not over-filled. Over filling the stud cavity with bulk insulation will impinge in the cavity created by the cavity battens and hence reduce its effectiveness, and may void warranty.

1.9.2 CAVITY BATTENS

Cavity battens provide the separation between the membrane on the wall frame and the cladding. Weathertex provides and recommends the use of Weathertex Cavity Battens which are 1220 x 45 x 9.5mm. Check your local regulations and/or certifiers for recommended batten thickness. If using battens other than Weathertex supplied cavity battens, fastener lengths should be increased to accommodate the batten thickness.

Refer to Weathertex Cavity Fix Construction Details when installing Weathertex cavity battens. Cavity battens must be fastened to framework at a maximum of 600mm centres. Butt-join the stud battens leaving a 5mm gap.

1.9.3 CAVITY CLOSER

To protect against vermin and other material entering the cavity, the base of the cavity must be sealed using the Weathertex Large or Small Cavity Closer. Designed not to interrupt airflow in the cavity, a cavity closer must be installed at the base of the wall, above window heads, inter-storey flashings and at other points where a cavity is created by the design. The bottom of the battens is inserted into the cavity closer.

- Use 10mm Small Cavity Closer for Selflok weatherboards,

Fix the cavity closer to the base plate at 300mm centres along the closer with 30 x 2.8mm flat head galvanised nails. Butt-join the cavity closers with a max 2mm gap and ensure they are fixed in a straight, level line. It is important that the openings in the cavity closer are kept clear and unobstructed to allow free drainage and ventilation from the top to the bottom of the cavity.

CAVITY
CONSTRUCTION
DETAILS AT

weathertex.com.au

1.9.4 INSTALLATION

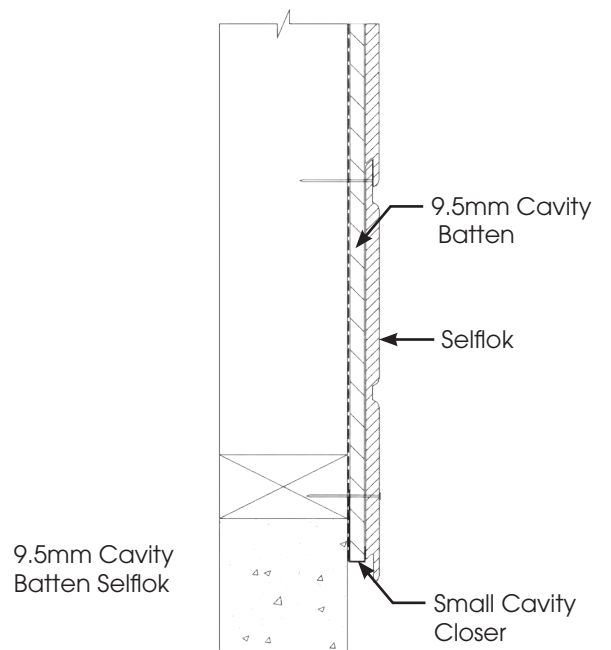
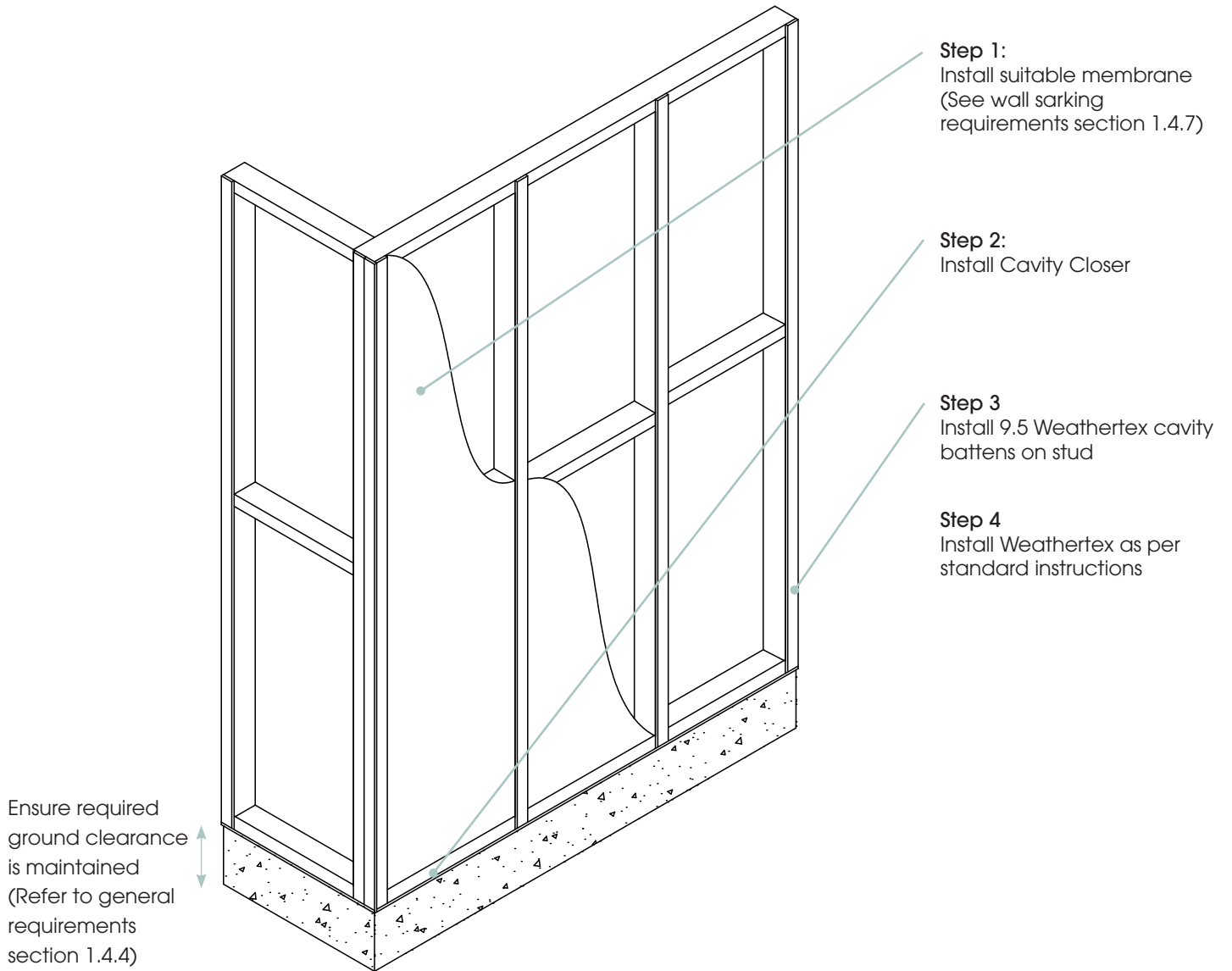

1.10 Physical Properties

WEATHERTEX WEATHERBOARDS AND ARCHITECTURAL PANELS.

WeatherTex weatherboards and architectural panels have been comprehensively tested to Australian and International Standards for verification of compliance to the Building Code of Australia.

MATERIAL DURABILITY PROPERTIES

The Product Specification Standard for WeatherTex is AS/NZS1859.4 - Wet Processed Fibreboard for Exterior Conditions (HB.E).

PROPERTY	STANDARD	RESULT	REQUIREMENT
Dimensions	AS NZS 4266.1	PASS	±2mm/m
Density	AS NZS 4266.1	1000 kg/m ³	> 750 kg/m ³
Bending Strength	AS NZS 4266.1	32 MPa	> 20 MPa
Modulus of Elasticity	AS NZS 4266.1	4500 MPa	> 2900 MPa
Equilibrium Moisture Content	AS NZS 4266.1	7.5%	7.5% ± 1% @ Factory gate
Dimensional Stability - Hygro-Expansivity	AS/NZS 4266.1	0.16% change in face dimensions over the range of 35%-80% relative humidity	N/A
Moisture Resistance	AS NZS 4266.1 - 24 Hour submersion	< 2% Swell	8% Max.
		< 6% Absorption	12.5% Max.

THERMAL AND ACOUSTIC PROPERTIES

PROPERTY	9.5MM COMPONENT VALUE	WEATHERTEX SYSTEM
Thermal Conductivity	0.22 W/mK	Where thermal and acoustically rated walls are required: WeatherTex can be used as part of wall systems to meet your specific performance requirements.
Thermal Resistance	0.04 m ² K/W	
Acoustic Properties (Rw)	System Dependant	

FIRE PROPERTIES

PROPERTY	STANDARD	RESULT	REQUIREMENT
Bushfire Attack Level (BAL)	AS 3959	Up to and including BAL 19	BCA: Vol. 1 - G5.2 BCA: Vol. 2 - 3.10.5
Average Specific Extinction Area	AS/NZS 3837	38.7 m ² /kg	BCA: Vol. 1 - C1.10
Material Group Number	AS/NZS 5637.1	Group 3	BCA: Vol. 1 - C1.10 BCA: Vol. 1 - Spec C1.10 - 4
Early Fire Hazard Indices	AS 1530.3	Ignitability : 12 Spread of Flame: 5 Heat Evolved : 4 Smoke Developed: 2	BCA: Vol. 1 - C1.10
Fire Resistance Level (FRL)	AS1530.4	Systems up to 120/120/120 available	BCA: Vol. 1 - Spec C1.1
Combustibility	BCA: Vol 1 - C1.1	Type C Compliant*	BCA: Vol 1 - C1.1

* A class 2,3 or 9c building with a rise in storeys of 2 may be of type C construction if requirements of C1.5 are satisfied.

MISCELLANEOUS PROPERTIES

Formaldehyde Classification	AS/NZS 4266.16 Test Method: <0.07 mg/L – Emission Class Super EO
WeatherTex contains no silica, resins, binders or added formaldehydes and the results above confirm the amount naturally present in hardwood timber is negligible and well below the acceptance level of 1.0mg/L (E1).	

2.1 SELFLOK Weatherboards

2.1.1 SELFLOK WEATHERBOARD BENEFITS

A favourite in the Weathertex family, Selflok flat panelled appearance is a fresh alternative to traditional lapped planks and perfectly suited for the modern home. Selflok weatherboards have the simplest horizontal shiplap joining method, which allows every board to self gauge. The precise routing gives the product that beautiful and unique ship lapped profile that makes it the first choice for many.

Features & Benefits

- Requires only standard carpentry tools.
- Durable with 25 years warranty (pre-primed) and 10 years warranty (Natural).
- Off stud joining option enables minimal waste and less timber stud layout.
- Lightweight product.

2.1.2 SELFLOK PRODUCT RANGE

Cladding is 3660mm in length and 9.5 mm in thickness. All selflok width is 298mm. ^ Refers to groove spacing.



SELFLOK ECOGROOVE
75^ SMOOTH



SELFLOK ECOGROOVE
150^ SMOOTH



SELFLOK ECOGROOVE
150^ WOODSMAN



SELFLOK ECOGROOVE
300^ SMOOTH



SELFLOK COLONIAL
SMOOTH



SELFLOK TEXWOOD
SMOOTH



SELFLOK MILLWOOD
SMOOTH



SELFLOK MILLWOOD
RUFF-SAWN



SELFLOK ECOGROOVE
75^ NATURAL

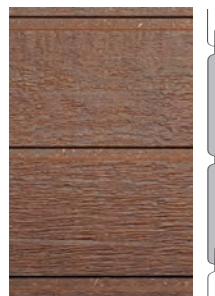

SELFLOK ECOGROOVE
150^ NATURAL



SELFLOK VGROOVE
150^ NATURAL



2.2 Accessories

2.2.1 WEATHERTEX ACCESSORIES *Made from Polycarbonate / ABS

MILLWOOD JOINERS

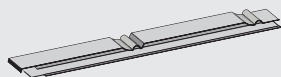

Available in Smooth & Ruff-Sawn

For traditional joining of Selflok Millwood 300mm weatherboards

COLONIAL JOINERS

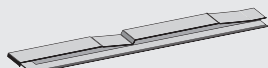

For traditional joining of Selflok Colonial Smooth

ECOGROOVE 75 JOINERS

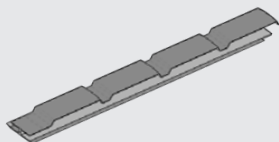

Available in Smooth

For traditional joining of Selflok Ecogroove 75 Smooth.

ECOGROOVE 150 JOINERS

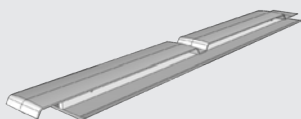

Available in Smooth & Woodsman

For traditional joining of Selflok Ecogroove 150 Smooth or Woodsman.

ECOGROOVE 300 JOINERS

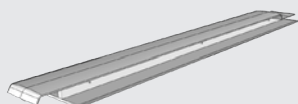

Available in Smooth

For traditional joining of Selflok Ecogroove 300 Smooth.

TEXWOOD JOINERS

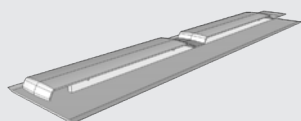

For traditional joining of Selflok Texwood Smooth

2.2.2 CAVITY WALL SYSTEM (Optional)

CAVITY CLOSER

L = 1830mm
 α = Lrg 20mm
 = Sml 10mm

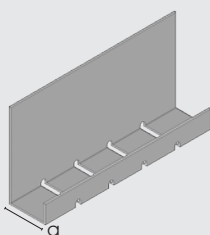







CAVITY BATTENS

1220mm x 45mm
 9.5mm thickness
 For all cavity constructions

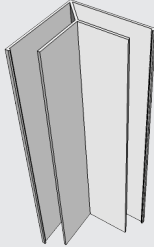
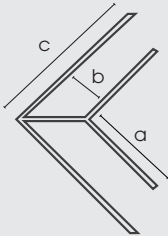
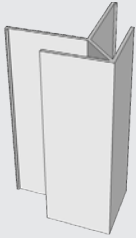
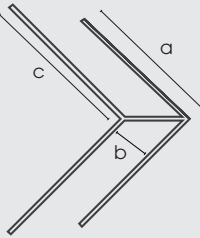
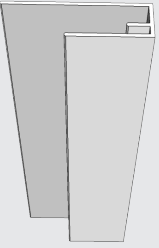

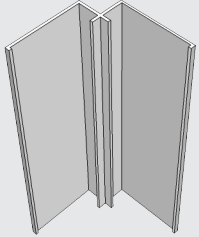
2.2.3 TRIMTEC ACCESSORIES

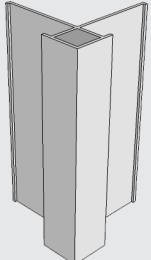
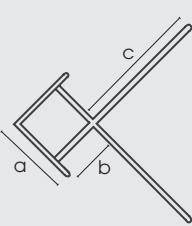
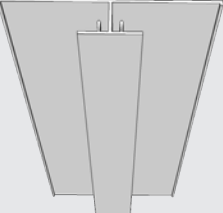
*Made from anodised aluminium

PRODUCT	PRODUCT IMAGE	LINE DRAWING	DIMENSION
SMALL INTERNAL LF CORNER			L = 3660mm a = 27mm b = 11mm c = 55mm
SMALL EXTERNAL LF CORNER			L = 3660mm a = 27mm b = 11mm c = 31mm
SMALL END STOP			L = 3660mm a = 27mm b = 11mm c = 45mm
SMALL INTERNAL CORNER			L = 3660mm a = 4mm b = 11mm c = 35mm
SMALL EXTERNAL CORNER			L = 3660mm a = 17mm b = 11mm c = 35mm
LONG VERTICAL JOINER			L = 3660mm a = 20mm b = 70mm

To view Weathertex product codes scan QR code.



2.3 Fasteners

Refer to the Wind Tables below when selecting a fastener. For wind ratings above N4 and C2 please contact Weathertex Technical on (ph: 1800 040 080). Installers must assure themselves that the appearance of the selected fastener is suitable for the intended use. Generally, head sizes in excess of 6mm or T and D head shaped nails may not produce a satisfactory finish on face fixed profiles.

- Stainless Steel ND50's recommended for ruff-sawn, woodsman & natural profiles. They are not recommended for smooth profiles as they may create an undesirable surface finish.
- 2.5mm Ring shank nails recommended for smooth profiles.
- Countersunk screws 2mm below the board surface & filled are recommended for completely concealed fixing of smooth profiles.

2.3.1 RESIDENTIAL WIND TABLE- AS 4055 WIND CLASSIFICATION

Frame	Extend fastener length when packing distance exceeds the following	Fastening Pattern	Fasteners	Non-Cyclonic Wind	Cyclonic Wind	Maximum Stud Spacing	
						General Areas of Walls	Within 1200mm of building edges
MGP10 Timber Minimum	Direct to frame	Traditional	Paslode ND50 SS Product Code: B20054A & B20665 (Brad & Fuel pack)	N1, N2, N3	C1	600	600
				N4	C2	600	450
		Traditional / Semi-Concealed	45mm x 2.5mm Ring Shank Nail	N1, N2, N3	C1	600	600
				N4	C2	600	450
MGP10 Timber Minimum	10mm	Traditional	Buildex Treated Pine 10g 8x50mm Countersunk Rib Head Screw Product Code: X503298	N1, N2	C1	600	600
				N3	C1	600	450
				N4	C2	450	400
0.55mm/ G550 Steel Minimum thickness	20mm	Traditional / Semi-Concealed	SCROOZ 8g x 42mm FibreFix Cement Board Screw Product Code: FFSC0842T	N1, N2, N3	C1	600	600
				N4	C2	600	450
0.75mm/ G550 Steel Minimum Thickness	12mm	Traditional	Iccons SD CSK COARSE C3 10-16 X 40mm Screw Product Code: SDCSC1040C3	N1, N2, N3	C1	600	600
				N4	C2	600	450
0.75mm/ G550 Steel Minimum Thickness	20mm	Traditional	Iccons SD CSK Wing Cs 10-16 x 45mm Screw Product Code: TP723	N1, N2	C1	600	600
				N3	C1	450	450
				N4	C2	450	300

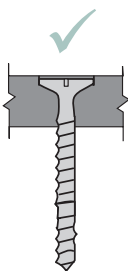

When using countersunk screws, these may be countersunk 2mm below the board surface and filled with a high quality proprietary grade, acrylic-based flexible paintable filler. Non-flexible epoxy based fillers are not suitable and may crack and fail with movement of construction components. If using a smart-bit style countersinking tool; the gauge of the screw must match the gauge of the tool to prevent movement issues. Screw holes should be spray primed after screwing. Filler should be sanded and area re-primed prior to painting.

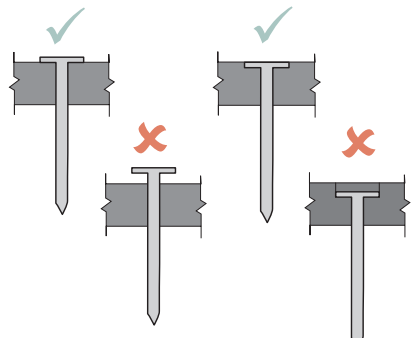

Nails must be finished flush to the board surface and not be punched and filled. Punching will significantly reduce the holding capacity of the fastener and damage the integrity of the board surface.

*AS/NZS 1170.2 wind loads table on next page.

2.3.2 COMMERCIAL WIND TABLE - AS/NZS 1170.2 WIND LOADS

Note: Serviceability Limit State (SLS) wind pressures are limited to +1 kPa, -1.5 kPa for V2.2.1/FV1.1 Weatherproofing

Frame	Extend fastener length when packing distance exceeds the following	Fastening Pattern	Fastener	Design Wind Pressure (Ultimate) kPa	Maximum Stud Spacing
MGP10 Timber Minimum	Direct Fix	Traditional	Paslode ND50 SS Product Code: B20054A & B20665 (Brad & Fuel pack)	1	600
				2.5	450
				4	400
				7	300
		Traditional / Semi-Concealed	45mm x 2.5mm Ring Shank Nail	1	600
				2.5	450
				4	400
				7	300
Semi-Concealed		6.5	300		
MGP10 Timber Minimum	9.5mm	Traditional	Buildex Treated Pine 10g 8x50mm Countersunk Rib Head Screw. Product Code: X503298	1	600
				2.5	450
				3.5	300
0.55mm/G550 Steel Minimum thickness	20mm	Traditional / Semi-Concealed	SCROOZ 8g x 42mm FibreFix Cement Board Screw Product Code: FFSC0842T	1	600
				2.5	450
		Traditional		4	400
				7	300
Semi-Concealed		6.5	300		
0.75mm/G550 Steel Minimum Thickness	12mm	Traditional	Iccons SD CSK COARSE C3 10-16 X 40mm Screw Product Code: SDCSC1040C3	1	600
				2.5	450
				4	400
				6	300
0.75mm/G550 Steel Minimum Thickness	20mm	Traditional	Iccons SD CSK Wing Cs 10-16 x 45mm Screw Product Code: TP723	1	600
				2	450
				2.5	400
		3.5	300		

Fastener & Wind Table Requirements and Recommendations

- Wind classification results have been conducted allowing for maximum packing distances specified in the tables. The fastener length must be increased to accommodate for the thickness of larger battens and/or additional packing materials to ensure the same penetration into the structural subframe.
- The above tables are relevant for on & off stud joining methods for timber and steel frames.
- The spans of the weatherboard shall be continuous spans of 2 spans or greater. Simply supported spans are not permitted.
- Span/150 serviceability limit state deflection criteria.
- All fasteners must be galvanised or suitably coated to resist corrosion for external application (Australian Standard AS 3566, Class 3 for screws). When installed in high corrosion zones such as coastal locations, fasteners (nails and screws) must be made of materials appropriate to the desired life of the system and geographical location. Stainless Steel Nails and Class 4 Screws may be necessary in these zones. The advice of the fastener supplier should be sought.
- ND Bradnails are not suitable for use with Semi-concealed fixing of Selflok products.
- Bradnails are not recommended for use on Smooth profiles as they may create an undesirable surface finish. Bradnails are an excellent choice for use with Woodsman and Ruff-Sawn profiles.
- Screws used underneath the lip for Semi-Concealed fastening must be flush and not countersunk.
- **For Natural range use stainless steel fasteners only.**

2.4 INSTALL: Selflok

The following product specific product installation instructions are applicable for both direct fix (timber frame) and cavity fix (timber and steel frame). Installation instructions in this section are to be used in conjunction with information and requirements given in previous sections and the national and state building codes.

2.4.1 BASE OF THE WALL & FRAME PREPARATION

Check and straighten sub-structures as required. Establish ground clearance and weatherboard overhang requirements. For cavity installation see cavity systems (section 1.9)/steel frames (section 1.8). For direct fix install wall sarking prior to installation, refer to AS 4200.2.

NOTE: For slab construction the plank may overhang the slab surface by 20-30mm.

Set a horizontal datum or base line around the perimeter of the building. Rest the bottom edge of the first row of weatherboards on datum line.

2.4.2 TRADITIONAL FASTENING

First Row: Fasten weatherboards with two face fasteners at each stud keeping fasteners 12mm minimum from ends, Fix first fixing into Weatherboard bottom edge and into the base plate. Second fixing approximately 170mm away from the bottom edge of the board.

Successive Rows: Rest the rebated edge of Selflok Weatherboards on the row below. Ensure there is proper engagement of the Selflok by applying downward pressure while fastening. Fix with two fasteners at each stud keeping fasteners 12mm minimum from ends, 30mm up from lower Weatherboard edges and approximately 140mm apart.

Row heights around corners should be checked as work progresses to prevent creep.

Please refer to Weathertex Direct Fix Installation – Selflok, Drgs. of 15.04.20 (9 pages), and Weathertex 9.5mm Cavity Installation – Selflok, Drgs. of 15.04.20 (9 pages) for details relevant to the Selflok Weatherproofing Appraisal.

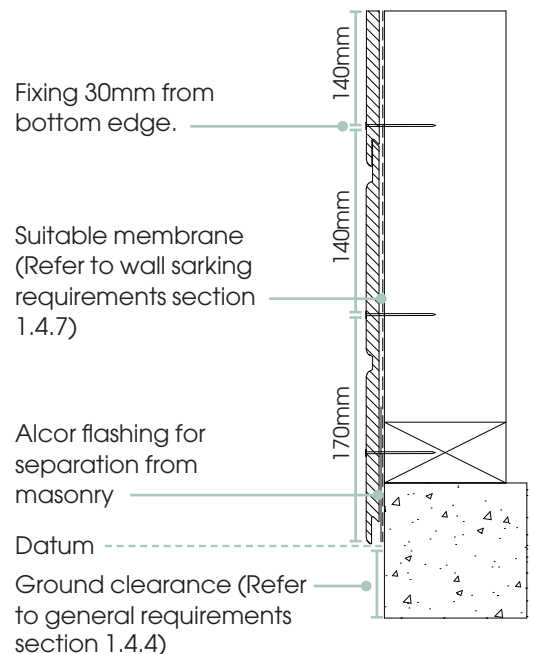

2.4.3 SEMI CONCEALED FASTENING

In some Wind Areas (see Sections: Fasteners 2.3), Selflok Weatherboards can also be fixed with one fixing concealed. In this case, one fixing must be placed 30mm from the bottom edge of the plank and the second placed 15mm below the top edge of the plank. The latter fixing is concealed by the plank above when it is installed. All other factors of installation are according to Traditional Fix instructions above.

Please refer to Weathertex Direct Fix Installation – Selflok, Drgs. of 15.04.20 (9 pages), and Weathertex 9.5mm Cavity Installation – Selflok, Drgs. of 15.04.20 (9 pages) for details relevant to the Selflok Weatherproofing Appraisal.

NOTE: ND Bradnails are not suitable for use with Semi-concealed fastening.

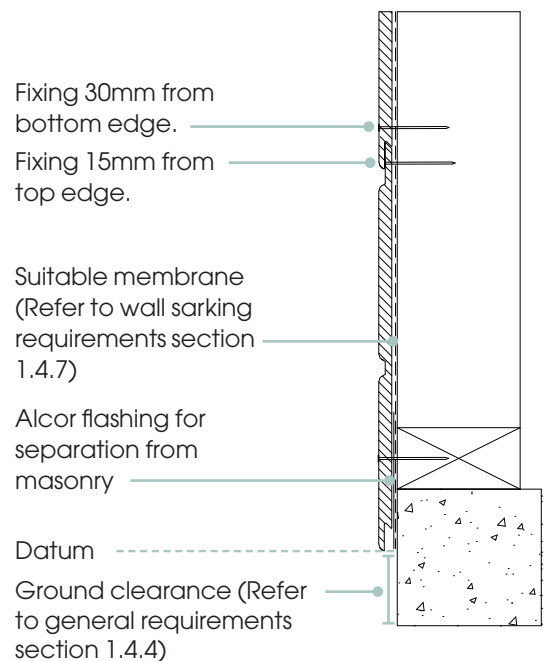

2.4.4 JOINING

To accommodate movement, Weathertex's joining methods have been designed to provide the correct spacing between adjoining planks, and cover changes in dimensions of the product for specific wall lengths. Refer to length of wall requirements when choosing a joining method.

2.4.4.1 JOINING: TRADITIONAL JOINER (PRE-PRIMED ONLY)

Form off-stud joints between Weatherboard ends using Weathertex Traditional PC/ABS Plank joiners. Each profile has its own moulded joiner to suit the particular product, refer to "Accessories" section. Form joints midway between studs and stagger randomly throughout the wall. Between each stud, joints must be supported by a continuous plank above and below (i.e. joiners may only align every second row). Reprime all cuts before forming joints. It is advisable to prepaint plank ends when using Traditional Joiners to avoid white lines either side of the Accessory after possible contraction of construction components in dry conditions. Joiners may be cut to fit at heads, sills and eaves.

1. Fit joiner to an installed plank. Nibs in the joiner correctly space the control joint - do not force tight to prevent breaking the nibs.
2. Rest the next plank on the plank below and firmly slide board across into the joiner.
3. Joiners provide a tight fit to the board. A hand plane may be used to skim the back corner of the joining edge in the case of tight joints.

NOTE: Traditional PC/ABS Joiners are not suitable for the natural range

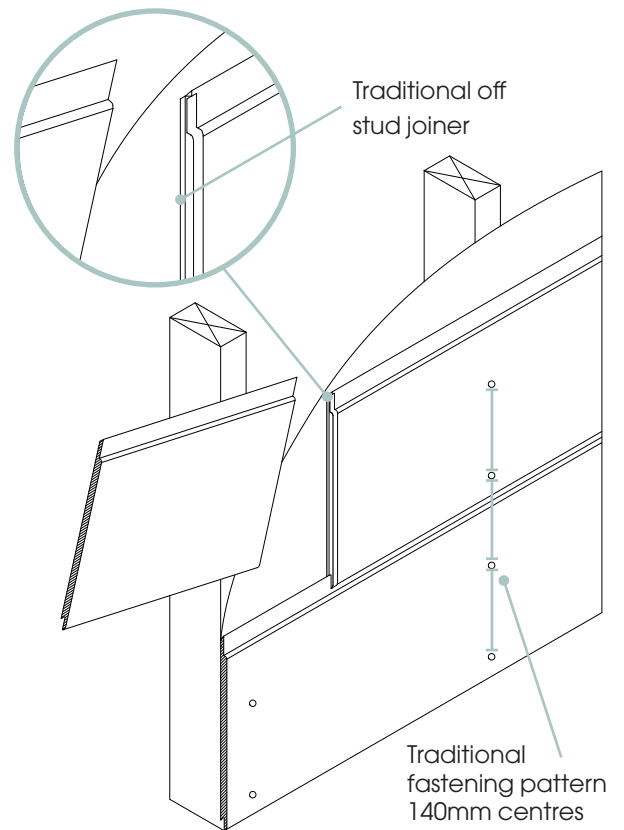

2.4.4.2 JOINING: LONG VERTICAL JOINER

For quick and sleek installation, align weatherboards to form a single vertical off-stud control joint using the Trimtec Long Vertical Joiner. It is advisable to prepaint plank ends when using Long Vertical Joiners to avoid white lines either side of the Accessory after possible contraction of construction components in dry conditions.

- Joiner must be supported by noggings at 600mm centres or positioned on a double stud.
 - Joiner may be etch primed and painted or left as the original uncoated anodised aluminium finish.
1. Attach the aluminium joiner to the stud frame through the back flange at 1200 centres with a flat head nail.
 2. Nibs in the joiner provide correct control joint spacing. Do not install tight to the nibs.
 3. Planks may be slightly bowed to fit between two vertical joiners or slid in place from the top before fastening off.

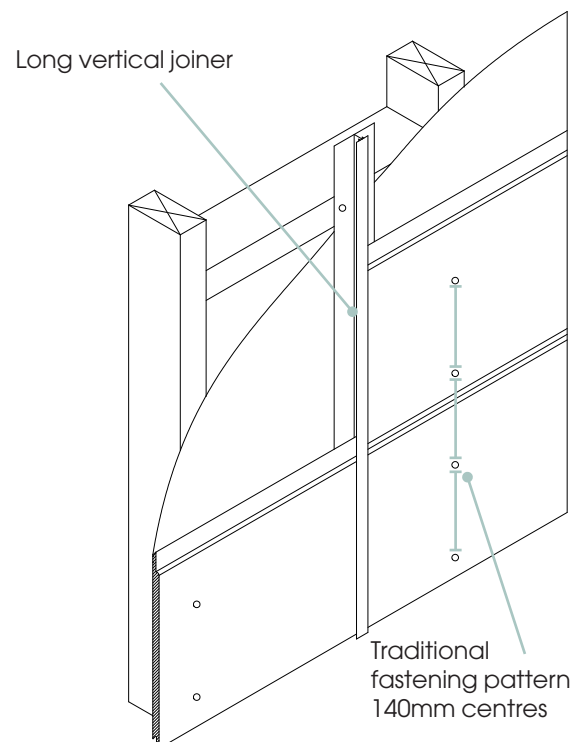

2.4 INSTALL: Selflok

2.4.4.3 BUTT-JOIN & 45° MITRE-JOIN

Selflok has two alternative On Stud joining methods:

- Butt-Join on stud - 3mm back flashed control gap.
 - 45° Mitre join on-stud - 3mm back flashed slip joint.
1. Ensure the join is supported by a single 90x45mm stud, or a double stud.
 2. Flash the join with Alcor flashing over the sarking at each planned joint
 3. Before installing the first weatherboard, run a 5mm bead of suitable, flexible sealant along the length of the Alcor flashing to seal the edge of the Selflok Weatherboard.
 4. Before installing the next weatherboard, leave a 3mm gap and run a 5mm bead of suitable, flexible sealant along the length of the Alcor flashing.

NOTES:

1. Refer to length of wall requirements when choosing butt / mitred joining methods as it may not be used on walls over 5.5m. For walls over 5.5m Weathertex recommends using the Long Vertical Joiner.
2. Natural Products are composed of unsealed natural hardwood timber which may occasionally exhibit tannin bleeding. Consideration must be taken if installing unsealed Weathertex products above porous or light coloured features.
3. Expansion and contraction of construction components with relative humidity can cause butt/mitred control joints to open and close after installation. If the aesthetic of open butt / mitre joints is an issue for the specific application, Weathertex recommends the Trimtec Long Vertical Aluminium Joining method.

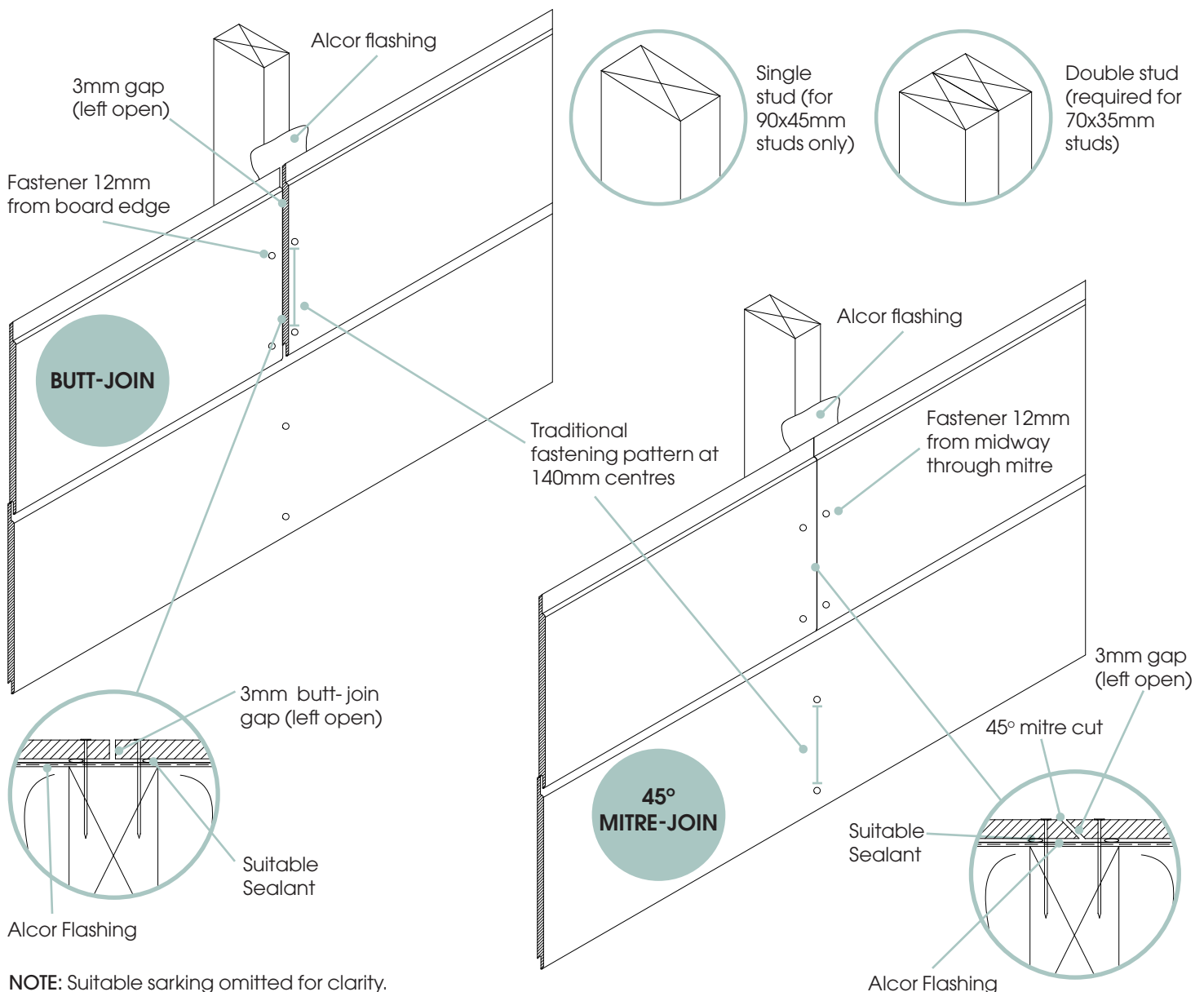

NOTE: Suitable sarking omitted for clarity.

MANUFACTURER'S WARRANTY

1. Weathertex Pty Ltd A.B.N 67 084 713 986 ("Weathertex") warrants that the Products supplied are of first quality, free from material defect in materials, design and workmanship, and in conformity with the technical specifications detailed in the published Weathertex Installation Guide that is current at the date of purchase. This statutory warranty applies for a period of 12 months from the date of purchase in addition to the following clauses.

2. Natural Board - Weathertex warrants that its Natural (Brown) Board Products will not rot, split or crack for a period of 10 (ten) years from the date of purchase when installed and maintained in accordance with Weathertex's current published materials.

Pre Primed Classic Shingles Plus, EcoWall and Rubix Panel - Weathertex warrants that its EcoWall Products will not rot, split or crack for a period of 10 (ten) years from the date of purchase when installed and maintained in accordance with Weathertex's current published materials.

Pre Primed Board - Weathertex warrants that its pre primed board Products will not rot, split or crack for a period of 25 (twenty-five) years from the date of purchase when prepared, installed and maintained in accordance with Weathertex's current published materials.

3. A reference to Products in these warranty terms and conditions does not include accessory products listed "Accessories" in the Weathertex Price List ("Accessory Products"). Weathertex warrants that the Accessory Products will be free from defect in material and workmanship for a period of 7 years from the date of purchase. For the purposes of clarity, the warranties provided in clause 1 and 2 do not apply to Accessory Products.

4. The benefits to the purchaser given by the warranties set out in clauses 1 to 3 are in addition to other rights and remedies of the purchaser under Australian Consumer Law in relation to the Weathertex products and accessories.

CONDITIONS OF THE WARRANTY

5. The warranties provided in clauses 1, 2 and 3 are only available to the original purchaser ("Purchaser") who provides Weathertex with proof of purchase and who makes the claim in writing within 30 days from the point in time when the defect becomes apparent or should have become apparent.

6. Weathertex will not be liable for any warranty claims made under clauses 1 and 2 if any of the following apply:

(a) the Products are not installed used or maintained in accordance with applicable instructions and/or specifications, including installation and site conditions provided by Weathertex (including the published Weathertex Installation Guide that is current at the date of purchase);

(b) the building in which the Products are installed does not comply with all relevant Building Codes and Regulations, Standards, and Council/Authority/Regulator requirements;

(c) the Purchaser has not complied with any service instructions which Weathertex may give or any subsequent request as to a modification of the Products which Weathertex may make from time to time in writing;

(d) the defect is caused by the use of materials, parts or accessory products that are not supplied, recommended, or approved by Weathertex;

(e) the Products are not maintained, prepared or installed by authorised installation contractors in circumstances where Weathertex has directed the Purchaser to ensure that the Products are maintained, prepared or installed by such authorised installation contractors; or

(f) the repair, rectification or replacement of the Products is required as a result of normal wear and tear or necessitated in whole or in part by the fault or negligence of any person other than Weathertex.

7. Further to clause 6 and without limiting clause 6, Weathertex under no circumstances will be liable for any claims, damages, or defects arising from or in any way attributable to:

(a) acts of God, fire, flood or other severe weather conditions or unusual climatic conditions;

(b) performance of paint/coatings applied to the Products;

(c) development of any algae, bacteria or fungi on the Products (whether on the exposed or unexposed surfaces);

(d) poor workmanship; or

(e) any other losses or damages (whether direct or indirect) including property damage or personal injury, consequential loss, economic loss or loss of profits arising in contract or negligence.

8. The Product is subject to natural variation in finish and presentation as a result of the manufacturing process. The purchaser / builder / installer must ensure the Product meets aesthetic expectations prior to installation. Subject to the terms and conditions of this warranty, after installation of the Product, Weathertex is not liable for claims arising from aesthetic surface variations if such variations were, or would upon reasonable inspection have been apparent prior to the installation.

REMEDIES

9. Should the Purchaser's warranty claim made under clauses 1 and/or 2

be valid within the relevant warranty period, then the remedy provided by Weathertex will be limited to either of the following (where possible) as chosen by Weathertex:

(a) Weathertex replacing the Products provided the claim is accepted by Weathertex and subject to such replacement Products being available in the manufacturing inventory at the time the claim is accepted by Weathertex. Otherwise, Weathertex will provide such replacement Products when they become available.

(b) Weathertex repairing the Products provided the claim is accepted by Weathertex.

10. Should the Purchaser's warranty claim made under clause 3 be valid, then the remedy provided by Weathertex will be limited to Weathertex replacing the Accessory Products provided the claim is accepted by Weathertex and subject to such replacement Accessory Products being available in the manufacturing inventory at the time the claim is accepted by Weathertex. Otherwise, Weathertex will provide such replacement Accessory Products when they become available.

11. The Purchaser is not entitled to any other remedies (that is apart from the remedies detailed in clauses 8 and 9) with respect to a warranty claim under clauses 1, 2 or 3.

12. This warranty cannot be relied upon by any other person and is not transferable.

13. Any replacement works will be conducted in accordance with the Building Codes and Regulations, Standards, and Council/Authority Regulator requirements applicable at the time of construction. Where the Building Codes and Regulations, Standards, and Council/ Authority Regulator requirements have changed after the Products were purchased, Weathertex will not be responsible for any costs associated with ensuring that the replacement works comply with the updated Building Codes and Regulations, Standards, and Council/Authority Regulator requirements.

14. Where an approved claim requires re-coating of the Products the Purchaser acknowledges and agrees to accept minor colour variations between the existing or original colour and the re-coated replacement Products or rectification areas.

15. Except as provided for in these terms and to the fullest extent permitted by law, all terms, statements, warranties and conditions whether express, implied, statutory or otherwise, relating to the Products, the Accessory Products, the subject matter of these terms or to these terms generally are excluded. Nothing contained herein excludes or modifies any rights the Purchaser may have under the Australian Competition and Consumer Act 2010 (or equivalent in other countries as determined by Weathertex in its sole discretion).

DISCLAIMER

16. Recommendations made by Weathertex are based on good building practice and are not a complete statement of all relevant data. As the installation of the Products is influenced by and relies on factors outside the control of Weathertex, Weathertex assumes no responsibility for works/ systems used in connection with the installation of the Products and their suitability to satisfy relevant Building Codes and Regulations, Standards, and Council/Authority /Regulator requirements.

17. Unless specifically stated otherwise, the warranties under clauses 1, 2 and 3 apply only to Weathertex products purchased and installed according to the Weathertex Installation Guide in Australia, New Zealand and the Weathertex International Installation Guide.

AUSTRALIAN CONSUMER LAW

18. Our goods come with guarantees that cannot be excluded under the Australian Consumer Law. You are entitled to a replacement or refund for a major failure and compensation for any other reasonably foreseeable loss or damage. You are also entitled to have the goods repaired or replaced if the goods fail to be of acceptable quality and the failure does not amount to a major failure.

MAKING WARRANTY CLAIMS

19. The claimant (being the Purchaser) must make all warranty claims in writing. The claimant must be the original purchaser of the Weathertex product and must retain the purchase receipt (in relation to the purchase of the product) as proof of purchase. Proof of purchase must be provided to Weathertex as part of the warranty claim.

Warranty claims (and claims for reasonable costs and expenses in making the claim as referred to in clause 18) can be addressed to Weathertex by post, fax or via e-mail as follows:

The Manager
Weathertex Pty Ltd
PO Box 21
Raymond Terrace NSW 2324
Phone 1800 040 080
Fax 1800 647 926
E-mail sales@weathertex.com.au

20. Weathertex will respond to all warranty claims. This response may include an inspection by a Weathertex representative of the installed Product. The claimant will bear all costs and expenses of making the claim. However reasonable costs and expenses will be reimbursed to the claimant in the event that the claim is accepted by Weathertex.

As of 14th August 2020.

Selflok Ecogroove 150 Smooth



Weathertex® is made in Australia by
Weathertex Pty Ltd ABN 67 084 713 986

PO Box 21, Raymond Terrace NSW 2324

CONTACT WEATHERTEX FOR INFORMATION OR ADVICE

1800 040 080 | weathertex.com.au

When specifying or installing Weathertex products, please make certain that you have the most current installation manual and technical information. To view the latest installation manual, scan the QR Code or visit weathertex.com.au

UPDATED 2ND FEBRUARY 2022

VERSION SC020222

