



Factory 13/5 Speedwell St

Somerville VIC 3912

☎ 03 5978 8755

☎ 1800 001 018

www.RoofExtenda.com.au

ROOF SAFETY ANCHOR INSTALLATION GUIDE

General Installation

1. Remove roofing tiles or lift roof sheets to achieve an opening to fit the Roof Extenda Roof Safety Anchor.
2. Bolt angle section and flat plate sandwiching the selected rafter at approx. 300mm from the roof's ridge with a minimum of 8 x M12 Hex Bolts, Nuts and Washer (Not supplied).
3. Replace the roof tiles or roof sheet, cutting a hole to allow the loop to penetrate the roof.

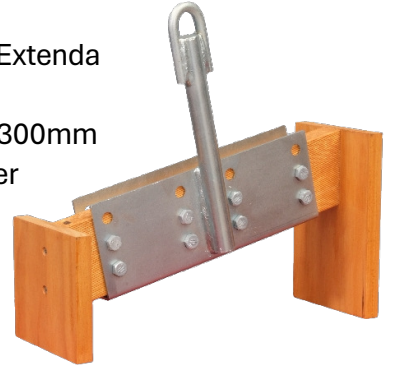

Care Instructions

Roof Extenda recommends painting the roof safety anchor prior to installation. The anchor is to be cleaned and inspected yearly and re-coated if required.

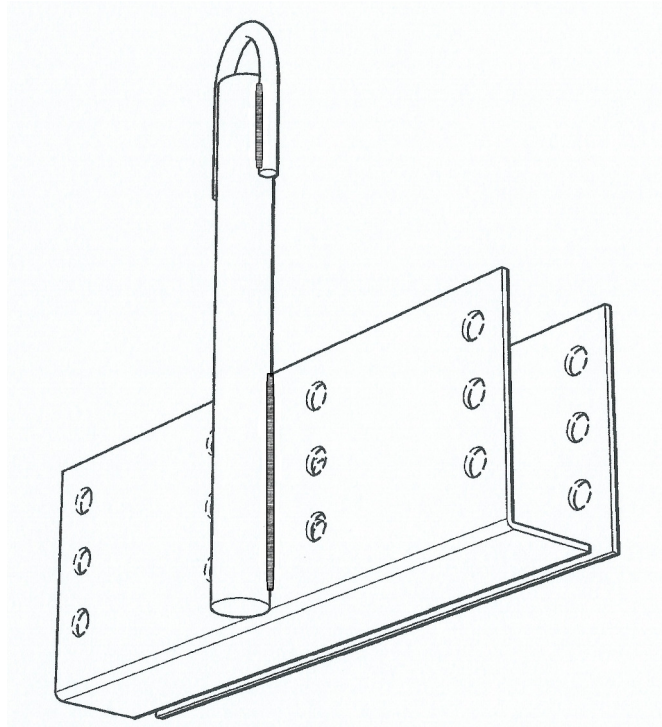

Note

Local Council or Shire approval may be required prior to construction. Roof Extenda accepts no responsibility for the type of construction undertaken. The Roof Safety Anchor has a 15Kn single person/limited freefall. Ensure the rafter/truss is capable of sustaining the rated loads, and all fittings are of a quality suitable to sustain the rated loads. Verification by a suitably qualified engineer may be required.

FlashRite Weather Seal

If using a FlashRite weather seal it is fitted to the top bracket.

- 1** Cut cone to exact corresponding pipe diameter. We recommend a sharp pair of scissors to cut our pipe flashing for the correct pipe size. Ensure there are no accidental nicks in the polymer, as this will continue to split/tear over time.

Tip: Ensure the blades are sharp with no contamination e.g. glue or any accumulated dirt.
- 2** Lubricate the top bracket with water prior to attaching the weather seal.
- 3** Attach the weather seal to the top bracket then wind the top bracket down to the desired height and lock the hex nut tightly.
- 4** Form the weather seal to the profile of the roof and mark out the position of the weather seal.
- 5** Slide the weather seal up the bracket to apply neutral cure sealant inside the area marked, press the weather seal into position and finish with a bead of sealant to the edges of the weather seal to complete the fitting.
- 6** Realign weather seal onto roof and fix with Class 3 or Class 4 hex head self-drilling screws minimum of 16mm long with a rubber washer.

CUT CONE TO EXACT
CORRESPONDING BRACKET
PIPE DIAMETER

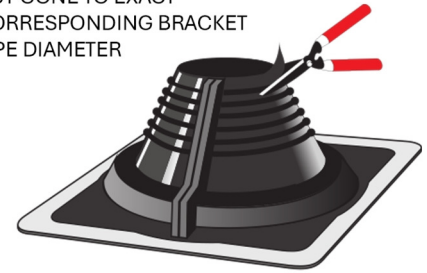

FORM TO
ROOF PROFILE

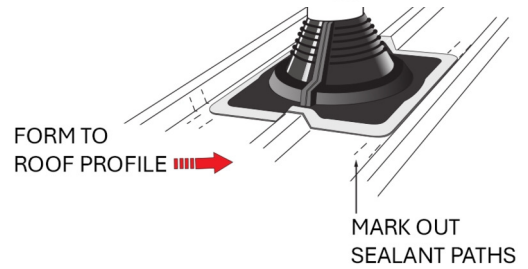

MARK OUT
SEALANT PATHS

LIFT FLASHING UP
TOP BRACKET PIPE

APPLY SEALANT ON
MARKED PATH

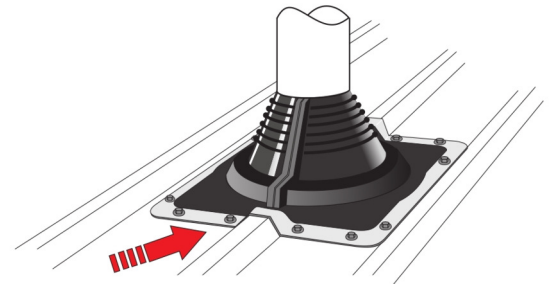
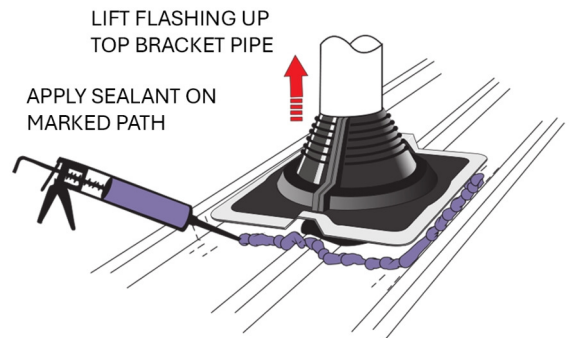

REALIGN FLASHING ONTO ROOF AND FIX
WITH APPROPRIATE FASTENERS. START HERE.

If Retro-Fitting a Weather Seal:

SPLIT SHOULDERS
WITH SCISSORS

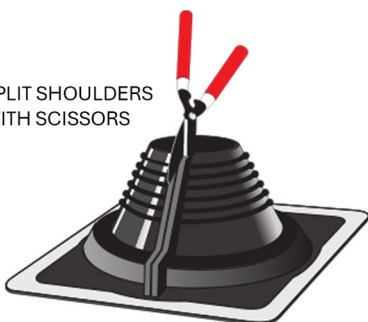

CRIMP FLASHING
SHOULDERS WITH
RETROFIT CLIPS.
FACE JOINT DOWNSTREAM.

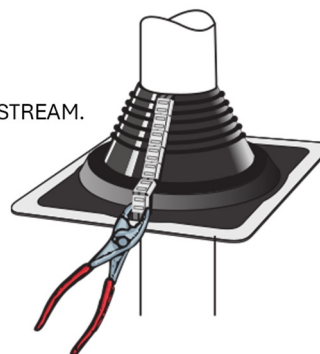

Flexatile

- 1** Ensure tiles are cleaned before installing the Flexatile flashing to ensure the butyl adhesive strips can have maximum effect when bonded to the tiles.
- 2** Cut the rubber cone at least 15mm smaller than the top bracket pipe's outside diameter with a sharp pair of scissors. Ensure there are no accidental nicks in the polymer, as this will continue to split/tear over time.

Tip: Ensure the blades are sharp with no contamination e.g. glue or any accumulated dirt.

- 3** Remove the middle lining from the underside of the flexatile.
- 4** Lubricate the top bracket with water and slide the flashing down the bracket.
- 5** Form an anti-capillary fold at top of base sheet.
- 6** Remove the protective backing from the underside of the flashing, that is covering the butyl adhesive strips.
- 7** Hand form the base all around the tile and apply pressure to the butyl adhesive side strip.

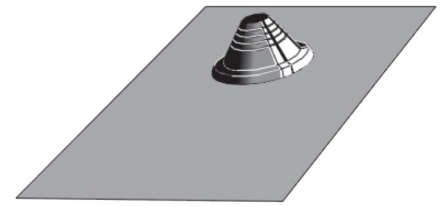

BASE SHEET CHOICE
a) ACRYFLASH
b) ALUMINIUM
c) RE-INFORCED POLYMER

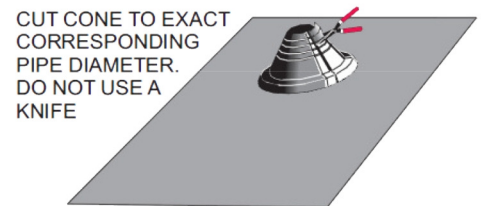

CUT CONE TO EXACT CORRESPONDING PIPE DIAMETER. DO NOT USE A KNIFE

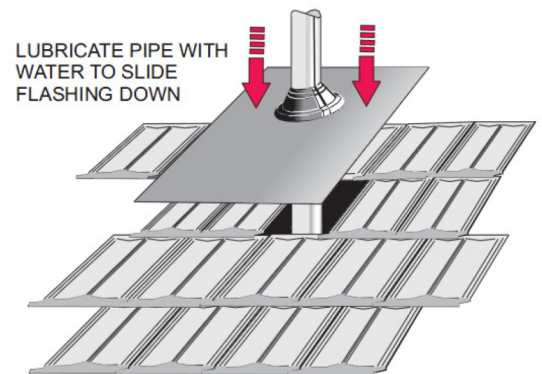

LUBRICATE PIPE WITH WATER TO SLIDE FLASHING DOWN

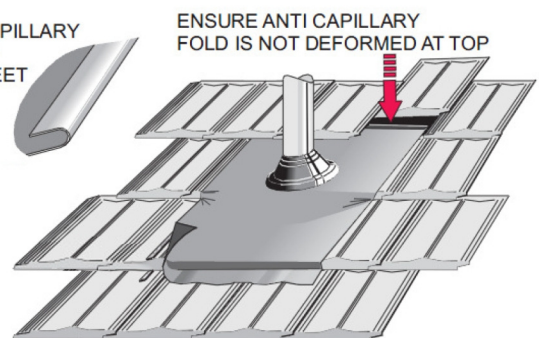

FORM AN ANTI-CAPILLARY FOLD AT THE TOP OF THE BASE SHEET

ENSURE ANTI CAPILLARY FOLD IS NOT DEFORMED AT TOP

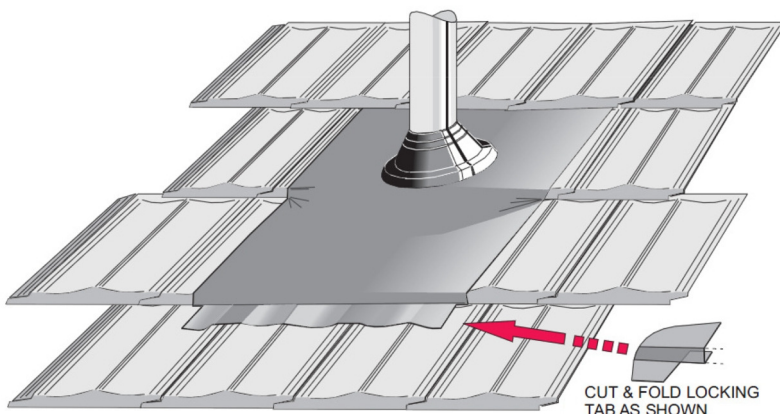

CUT & FOLD LOCKING TAB AS SHOWN